

Pressure Measurement

Transmitters for applications with advanced requirements (Advanced)

SITRANS P DS III

Technical description

1

Overview



SITRANS P DS III pressure transmitters are digital pressure transmitters featuring extensive user-friendliness and high accuracy. The parameterization is performed using control keys or via HART, PROFIBUS-PA or FOUNDATION Fieldbus interface.

Extensive functionality enables the pressure transmitter to be precisely adapted to the plant's requirements. Operation is very simple in spite of the numerous setting options.

Transmitters with type of protection "Intrinsic safety" and "Explosion-proof" may be installed within potentially explosive atmospheres (zone 1) or in zone 0. The transmitters are provided with an EC type examination certificate and comply with the corresponding harmonized European standards (ATEX).

The transmitters can be equipped with various designs of remote seals for special applications such as the measurement of highly viscous substances.

Various versions of the DS III pressure transmitters are available for measuring:

- Gauge pressure
- Absolute pressure
- Differential pressure
- Level
- Volume level
- Mass level
- Volume flow
- Mass flow

Benefits

- High quality and service life
- High reliability even under extreme chemical and mechanical loads
- For aggressive and non-aggressive gases, vapors and liquids
- Extensive diagnosis and simulation functions
- Separate replacement of measuring cell and electronics without recalibration
- Minimum conformity error
- Good long-term stability
- Wetted parts made of high-grade materials (e.g. stainless steel, Hastelloy, gold, Monel, tantalum)

- Infinitely adjustable span from 0.01 bar to 700 bar (0.15 psi to 10153 psi) for DS III with HART interface
- Nominal measuring range from 1 bar to 700 bar (14.5 psi to 10153 psi) for DS III with PROFIBUS PA and FOUNDATION Fieldbus interface
- High measuring accuracy
- Parameterization over control keys and HART or PROFIBUS PA, or FOUNDATION Fieldbus interface.

Application

The pressure transmitters of the DS III series, can be used in industrial areas with extreme chemical and mechanical loads. Electromagnetic compatibility in the range 10 kHz to 1 GHz makes the DS III pressure transmitters suitable for locations with high electromagnetic emissions.

Pressure transmitters with type of protection "Intrinsic safety" and "Explosion-proof" may be installed within potentially explosive atmospheres (zone 1) or in zone 0. The pressure transmitters are provided with an EC type examination certificate and comply with the corresponding harmonized European standards (ATEX).

Pressure transmitters with the type of protection "Intrinsic safety" for use in zone 0 may be operated with power supply units of category "ia" and "ib".

The transmitters can be equipped with various designs of remote seals for special applications such as the measurement of highly viscous substances.

The pressure transmitter can be programmed locally using the 3 control buttons or externally via HART or PROFIBUS PA or FOUNDATION Fieldbus interface.

Pressure Measurement

Transmitters for applications with advanced requirements (Advanced)
SITRANS P DS III

Technical description

Pressure transmitter for gauge pressure

Measured variable: Gauge pressure of aggressive and non-aggressive gases, vapors and liquids.

Span (infinitely adjustable)

for DS III with HART: 0.01 bar to 700 bar (0.15 psi to 10153 psi)

Nominal measuring range

for DS III with PROFIBUS PA and FOUNDATION Fieldbus:
1 bar to 700 bar (14.5 psi to 10153 psi)

Pressure transmitters for absolute pressure

Measured variable: Absolute pressure of aggressive and non-aggressive gases, vapors and liquids.

Span (infinitely adjustable)

for DS III with HART: 8.3 mbar a ... 100 bar a (0.12 ... 1450 psi a)

Nominal measuring range

for DS III with PROFIBUS PA and FOUNDATION Fieldbus:
250 mbar a ... 100 bar a (3.6 ... 1450 psi a)

There are two series:

- Gauge pressure series
- Differential pressure series

Pressure transmitters for differential pressure and flow

Measured variables:

- Differential pressure
- Small positive or negative pressure
- Flow $q \sim \sqrt{\Delta p}$ (together with a primary differential pressure device (see Chapter "Flow Meters"))

Span (infinitely adjustable)

for DS III with HART: 1 mbar ... 30 bar (0.0145 ... 435 psi)

Nominal measuring range

for DS III with PROFIBUS PA and FOUNDATION Fieldbus:
20 mbar ... 30 bar (0.29 ... 435 psi)

Pressure transmitters for level

Measured variable: Level of aggressive and non-aggressive liquids in open and closed vessels.

Span (infinitely adjustable)

for DS III with HART: 25 mbar ... 5 bar (0.363 ... 72.5 psi)

Nominal measuring range

for DS III with PROFIBUS PA and FOUNDATION Fieldbus:
250 mbar ... 5 bar (3.63 ... 72.5 psi)

Nominal diameter of the mounting flange

- DN 80 or DN 100
- 3 inch or 4 inch

In the case of level measurements in open containers, the low-pressure connection of the measuring cell remains open (measurement "compared to atmospheric").

In the case of measurements in closed containers, the lower-pressure connection has to be connected to the container in order to compensate the static pressure.

The wetted parts are made from a variety of materials, depending on the degree of corrosion resistance required.

Design

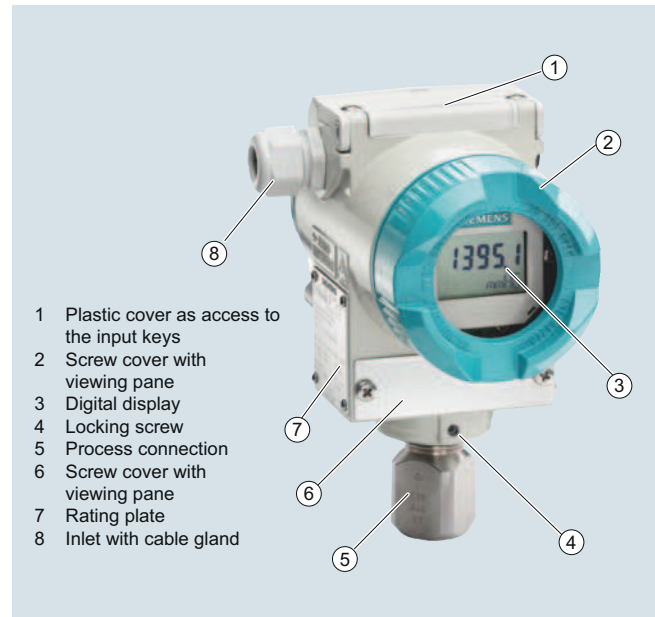

Front view

The transmitter consists of various components depending on the order. The possible versions are listed in the ordering information. The components described below are the same for all transmitters.

The rating plate (7, Figure "Front view") with the Article No. is located on the side of the housing. The specified number together with the ordering information provide details on the optional design details and on the possible measuring range (physical properties of built-in sensor element).

The approval label is located on the opposite side.

The housing is made of die-cast aluminium or stainless steel precision casting. A round cover (6) is screwed on at the front and rear of the housing. The front cover can be fitted with a viewing pane so that the measured values can be read directly on the display. The inlet (8) for the electrical connection is located either on the left or right side. The unused opening on the opposite side is sealed by a blanking plug. The protective earth connection is located on the rear of the housing.

The electrical connections for the power supply and screen are accessible by unscrewing the rear cover. The bottom part of the housing contains the measuring cell with process connection (5). The measuring cell is prevented from rotating by a locking screw (4). As the result of this modular design, the measuring cell and the electronics can be replaced separately from each other. The set parameter data are retained.

At the top of the housing is a plastic cover (1), which hides the input keys.

Example for an attached measuring point label

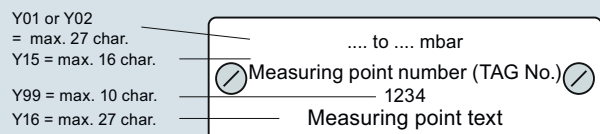

Function

Operation of electronics with HART communication

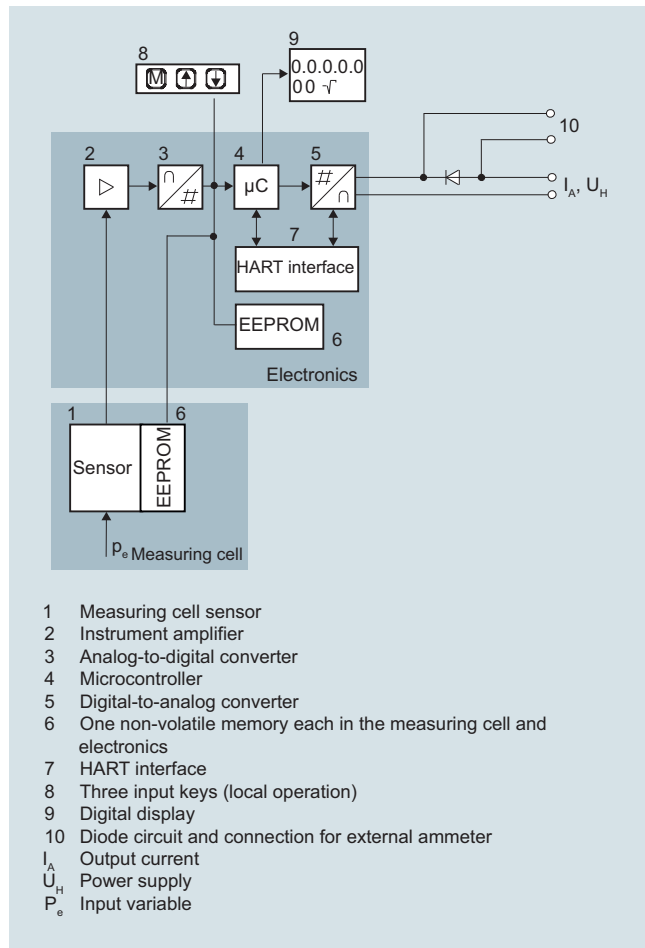

Function diagram of electronics

The bridge output voltage created by the sensor (1, Figure "Function diagram of the electronics") is amplified by the measuring amplifier (2) and digitized in the analog-to-digital converter (3). The digital information is evaluated in a microcontroller, its linearity and temperature response corrected, and converted in a digital-to-analog converter (5) into an output current of 4 to 20 mA.

The diode circuit (10) protects against incorrect polarity.

The data specific to the measuring cell, the electronics data, and the parameter data are stored in the two non-volatile memories (6). The one memory is coupled to the measuring cell, the other to the electronics. As the result of this modular design, the electronics and the measuring cell can be replaced separately from each other.

Using the 3 input keys (8) you can parameterize the pressure transmitter directly at the measuring point. The input buttons can also be used to control the view of the results, the error messages and the operating modes on the display (9).

The HART modem (7) permits parameterization using a protocol according to the HART specification.

The pressure transmitters with spans ≤ 63 bar measure the input pressure compared to atmosphere, transmitters with spans ≥ 160 bar compared to vacuum.

Operation of electronics with PROFIBUS PA communication

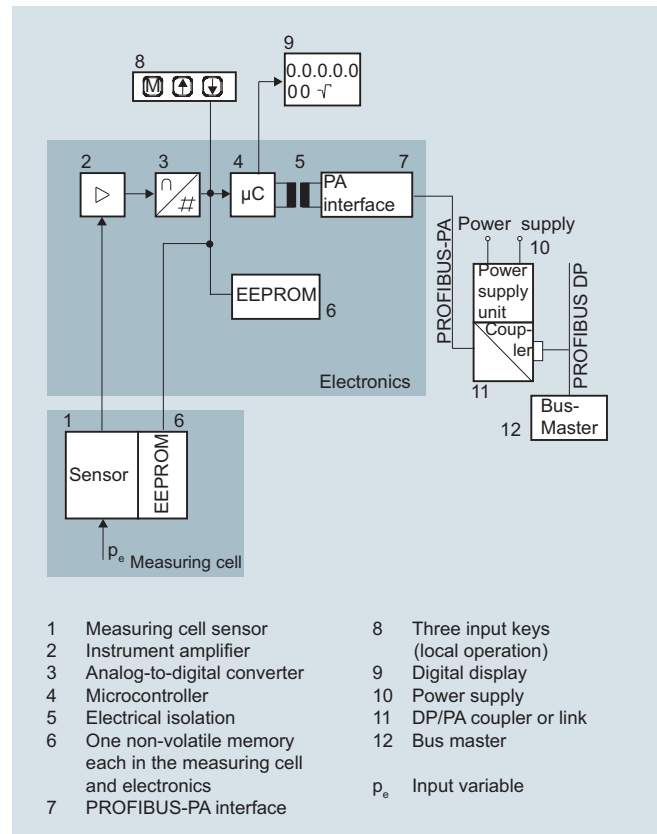

Function diagram of electronics

The bridge output voltage created by the sensor (1, Figure "Function diagram of the electronics") is amplified by the measuring amplifier (2) and digitized in the analog-to-digital converter (3). The digital information is evaluated in the microcontroller, its linearity and temperature response corrected, and provided on the PROFIBUS PA through an electrically isolated PA interface (7).

The data specific to the measuring cell, the electronics data, and the parameter data are stored in the two non-volatile memories (6). The one memory is coupled to the measuring cell, the other to the electronics. As the result of this modular design, the electronics and the measuring cell can be replaced separately from each other.

Using the three input buttons (8) you can parameterize the pressure transmitter directly at the measuring point. The input buttons can also be used to control the view of the results, the error messages and the operating modes on the display (9).

The results with status values and diagnostic values are transferred by cyclic data transmission on the PROFIBUS PA. Parameterization data and error messages are transferred by acyclic data transmission. Special software such as SIMATIC PDM is required for this.

Pressure Measurement

Transmitters for applications with advanced requirements (Advanced)
SITRANS P DS III

Technical description

Operation of electronics with FOUNDATION Fieldbus communication

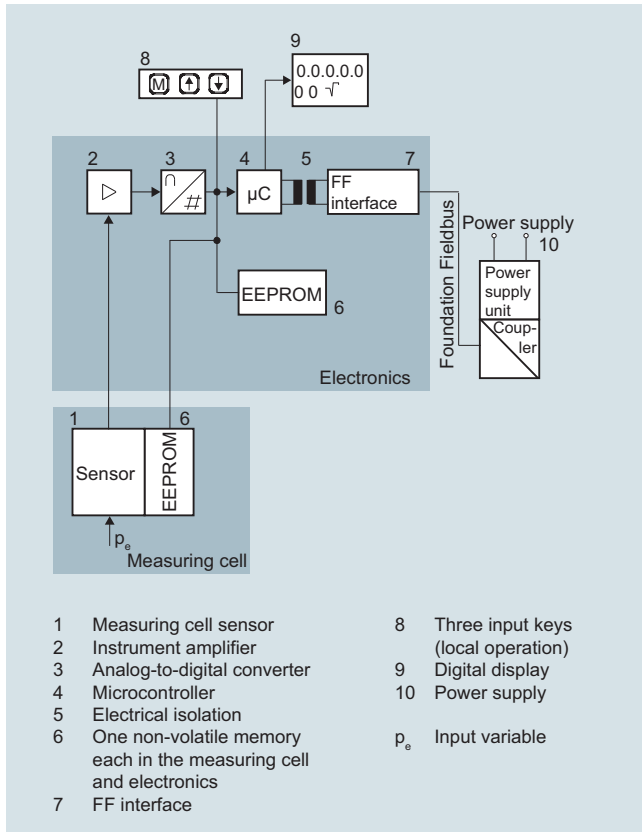

Function diagram of electronics

The bridge output voltage created by the sensor (1, Figure "Function diagram of electronics") is amplified by the measuring amplifier (2) and digitized in the analog-to-digital converter (3). The digital information is evaluated in the microcontroller, its linearity and temperature response corrected, and provided on the FOUNDATION Fieldbus through an electrically isolated FOUNDATION Fieldbus interface (7).

The data specific to the measuring cell, the electronics data, and the parameter data are stored in the two non-volatile memories (6). The one memory is coupled to the measuring cell, the other to the electronics. As the result of this modular design, the electronics and the measuring cell can be replaced separately from each other.

Using the three input buttons (8) you can parameterize the pressure transmitter directly at the measuring point. The input buttons can also be used to control the view of the results, the error messages and the operating modes on the display (9).

The results with status values and diagnostic values are transferred by cyclic data transmission on the FOUNDATION Fieldbus. Parameterization data and error messages are transferred by acyclic data transmission. Special software such as National Instruments Configurator is required for this.

Mode of operation of the measuring cells

Measuring cell for gauge pressure

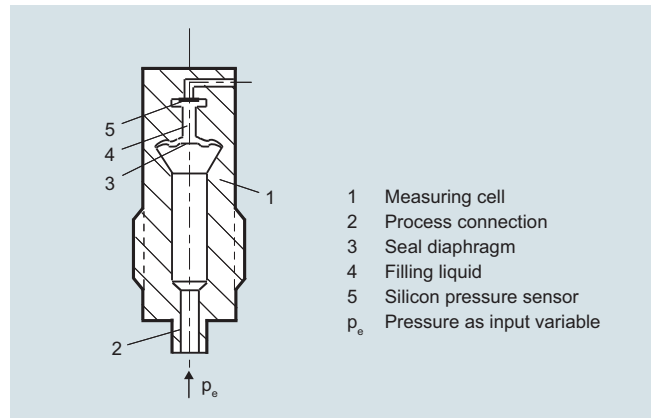

Measuring cell for gauge pressure, function diagram

The pressure p_e is applied through the process connection (2, Figure "Measuring cell for gauge pressure, function diagram") to the measuring cell (1). This pressure is subsequently transmitted further through the seal diaphragm (3) and the filling liquid (4) to the silicon pressure sensor (5) whose measuring diaphragm is then flexed. This changes the resistance of the four piezo-resistors fitted in the diaphragm in a bridge circuit. This change in resistance results in a bridge output voltage proportional to the absolute pressure.

Measuring cell for gauge pressure with front-flush diaphragm

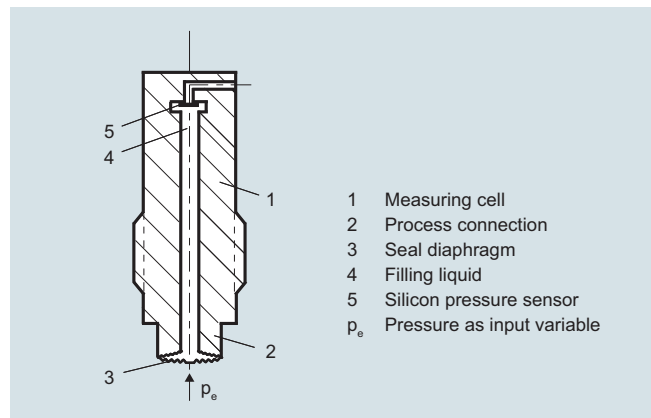

Measuring cell for gauge pressure, with front-flush diaphragm for paper industry, function diagram

The pressure p_e is applied through the process connection (2, Figure "Measuring cell for gauge pressure, with front-flush diaphragm for paper industry, function diagram") to the measuring cell (1). This pressure is subsequently transmitted further through the seal diaphragm (3) and the filling liquid (4) to the silicon pressure sensor (5) whose measuring diaphragm is then flexed. This changes the resistance of the four piezo-resistors fitted in the diaphragm in a bridge circuit. This change in resistance results in a bridge output voltage proportional to the absolute pressure.

Measuring cell for absolute pressure from gauge pressure series

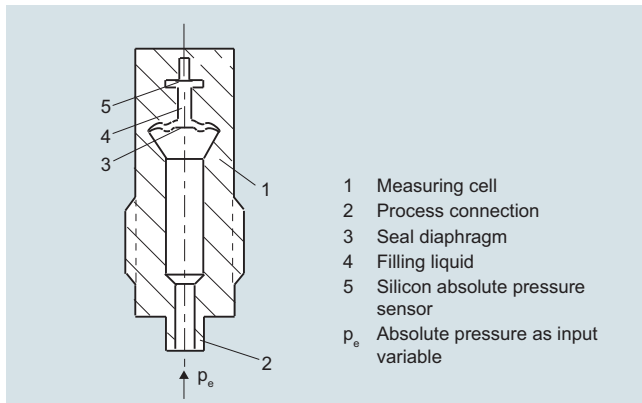

Measuring cell for absolute pressure from the pressure series, function diagram

The absolute pressure p_e is transmitted through the seal diaphragm (3, Figure "Measuring cell for absolute pressure from pressure series, gauge pressure, function diagram") and the filling liquid (4) to the silicon absolute pressure sensor (5) whose measuring diaphragm is then flexed. This changes the resistance of the four piezo-resistors fitted in the diaphragm in a bridge circuit. This change in resistance results in a bridge output voltage proportional to the absolute pressure.

Measuring cell for absolute pressure from differential pressure series

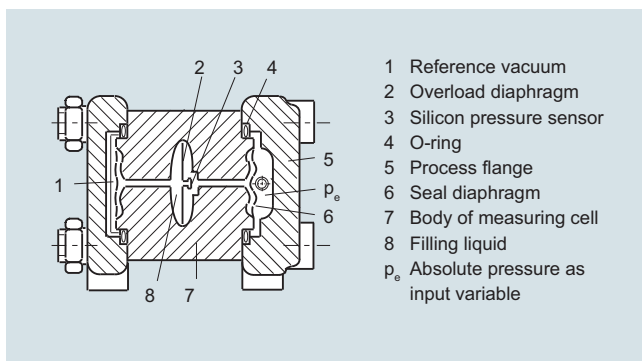

Measuring cell for absolute pressure from differential pressure series, function diagram

The input pressure p_e is transmitted through the seal diaphragm (6, Figure "Measuring cell for absolute pressure from differential pressure series, function diagram") and the filling liquid (8) to the silicon pressure sensor (3).

The difference in pressure between the input pressure p_e and the reference vacuum (1) on the low-pressure side of the measuring cell flexes the measuring diaphragm. This changes the resistance of the four piezo-resistors fitted in the diaphragm in a bridge circuit. This change in resistance results in a bridge output voltage proportional to the absolute pressure.

An overload diaphragm is installed to provide protection from overloads. If the measuring limits are exceeded, the overload diaphragm (2) is flexed until the seal diaphragm rests on the body of the measuring cell (7), thus protecting the silicon pressure sensor from overloads.

Measuring cell for differential pressure and flow

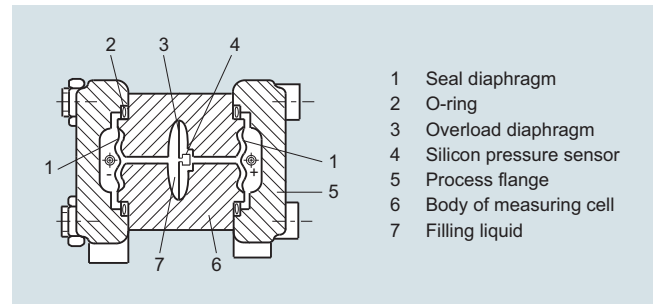

Measuring cell for differential pressure and flow, function diagram

The differential pressure is transmitted through the seal diaphragms (1, Figure "Measuring cell for differential pressure and flow, function diagram") and the filling liquid (7) to the silicon pressure sensor (4).

The measuring diaphragm is flexed by the applied differential pressure. This changes the resistance of the four piezo-resistors fitted in the diaphragm in a bridge circuit. This change in resistance results in a bridge output voltage proportional to the differential pressure.

An overload diaphragm is installed to provide protection from overloads. If the measuring limits are exceeded, the overload diaphragm (3) is flexed until the seal diaphragm rests on the body of the measuring cell (6), thus protecting the silicon pressure sensor from overloads.

Measuring cell for level

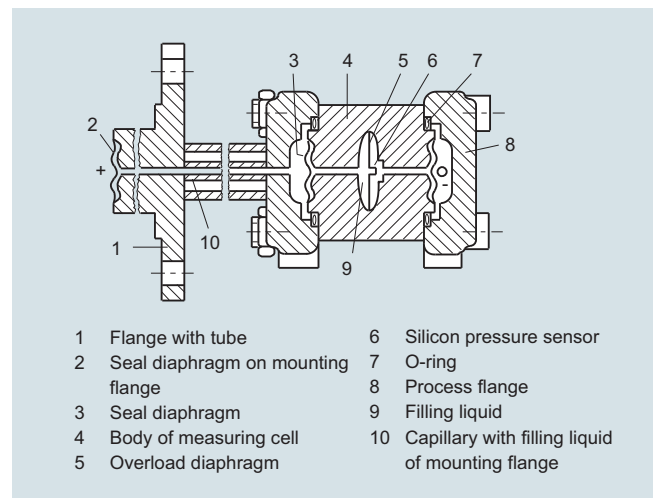

Measuring cell for level, function diagram

The input pressure (hydrostatic pressure) acts hydraulically on the measuring cell through the seal diaphragm on the mounting flange (2, Figure "Measuring cell for level, function diagram"). This differential pressure is subsequently transmitted further through the measuring cell (3) and the filling liquid (9) to the silicon pressure sensor (6) whose measuring diaphragm is then flexed.

This changes the resistance of the four piezo-resistors fitted in the diaphragm in a bridge circuit.

This change in resistance results in a bridge output voltage proportional to the differential pressure.

An overload diaphragm is installed to provide protection from overloads. If the measuring limits are exceeded, the overload diaphragm (5) is flexed until the seal diaphragm rests on the body of the measuring cell (4), thus protecting the silicon pressure sensor from overloads.

Pressure Measurement

Transmitters for applications with advanced requirements (Advanced)
SITRANS P DS III

1

Technical description

Parameterization DS III

Depending on the version, there are a range of options for parameterizing the pressure transmitter and for setting or scanning the parameters.

Parameterization using the input buttons (local operation)

With the input buttons you can easily set the most important parameters without any additional equipment.

Parameterization using HART

Parameterization using HART is performed with a HART Communicator or a PC.

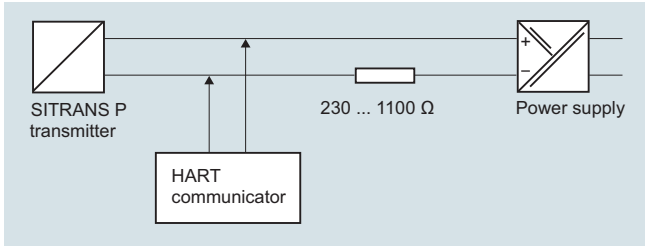

Communication between a HART Communicator and a pressure transmitter

When parameterizing with the HART Communicator, the connection is made directly to the 2-wire cable.

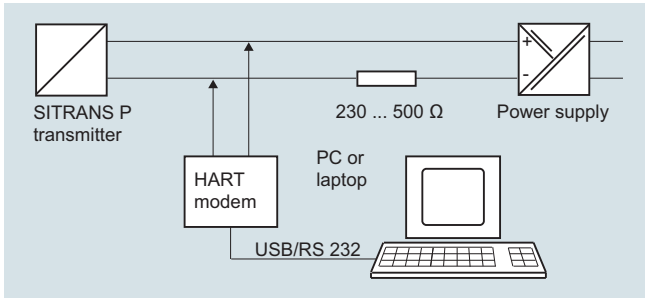

HART communication between a PC communicator and a pressure transmitter

When parameterizing with a PC, the connection is made through a HART modem.

The signals needed for communication in conformity with the HART 5.x or 6.x protocols are superimposed on the output current using the Frequency Shift Keying (FSK) method.

Adjustable parameters, DS III with HART

Parameters	Input keys (DS III HART)	HART communication
Start of scale	x	x
Full-scale value	x	x
Electrical damping	x	x
Start-of-scale value without application of a pressure ("Blind setting")	x	x
Full-scale value without application of a pressure ("Blind setting")	x	x
Zero adjustment	x	x
current transmitter	x	x
Fault current	x	x
Disabling of buttons, write protection	x	x ¹⁾
Type of dimension and actual dimension	x	x
Characteristic (linear / square-rooted)	x ²⁾	x ²⁾
Input of characteristic		x
Freely-programmable LCD		x
Diagnostic functions		x

1) Cancel apart from write protection
2) Only differential pressure

Diagnostic functions for DS III with HART

- Zero correction display
- Event counter
- Limit transmitter
- Saturation alarm
- Slave pointer
- Simulation functions
- Maintenance timer

Available physical units of display for DS III with HART

Table style: Technical specifications 2

Physical variable	Physical dimensions
Pressure (setting can also be made in the factory)	Pa, MPa, kPa, bar, mbar, torr, atm, psi, g/cm ² , kg/cm ² , inH ₂ O, inH ₂ O (4 °C), mmH ₂ O, ftH ₂ O (20 °C), inHg, mmHg
Level (height data)	m, cm, mm, ft, in
Volume	m ³ , dm ³ , hl, yd ³ , ft ³ , in ³ , US gallon, Imp. gallon, bushel, barrel, barrel liquid
Mass	g, kg, t, lb, Ston, Lton, oz
volume flow	m ³ /d, m ³ /h, m ³ /s, l/min, l/s, ft ³ /d, ft ³ /min, ft ³ /s, US gallon/min, US gallon/s
Mass flow	t/d, t/h, t/min, kg/d, kg/h, kg/min, kg/s, g/d, g/h, g/min, g/s, lb/d, lb/h, lb/min, lb/s, LTon/d, LTon/h, STon/d, STon/h, STon/min
Temperature	K, °C, °F, °R
Miscellaneous	%, mA

Parameterization through PROFIBUS PA interface

Fully digital communication through PROFIBUS PA, profile 3.0, is particularly user-friendly. Through the PROFIBUS the DS III with PROFIBUS PA is connected to a process control system, e. g. SIMATIC PSC 7. Communication is possible even in a potentially explosive environment.

For parameterization through PROFIBUS you need suitable software, e.g. SIMATIC PDM (Process Device Manager).

Parameterization through FOUNDATION Fieldbus interface

Fully digital communication through FOUNDATION Fieldbus is particularly user-friendly. Through the FOUNDATION Fieldbus the DS III with FOUNDATION Fieldbus is connected to a process control system. Communication is possible even in a potentially explosive environment.

For parameterization through the FOUNDATION Fieldbus you need suitable software, e.g. National Instruments Configurator.

Adjustable parameters for DS III with PROFIBUS PA and FOUNDATION Fieldbus

Parameters	Input keys	PROFIBUS PA and FOUNDATION Fieldbus interface
Electrical damping	x	x
Zero adjustment (correction of position)	x	x
Buttons and/or function disabling	x	x
Source of measured-value display	x	x
Physical dimension of display	x	x
Position of decimal point	x	x
Bus address	x	x
Adjustment of characteristic	x	x
Input of characteristic		x
Freely-programmable LCD		x
Diagnostics functions		x

Diagnostic functions for DS III with PROFIBUS PA and FOUNDATION Fieldbus

- Event counter
- Slave pointer
- Maintenance timer
- Simulation functions
- Display of zero correction
- Limit transmitter
- Saturation alarm

Physical dimensions available for the display

Physical variable	Physical dimensions
Pressure (setting can also be made in the factory)	MPa, kPa, Pa, bar, mbar, torr, atm, psi, g/cm ² , kg/cm ² , mmH ₂ O, mmH ₂ O (4 °C), inH ₂ O, inH ₂ O (4 °C), ftH ₂ O (20 °C), mmHg, inHg
Level (height data)	m, cm, mm, ft, in, yd
Volume	m ³ , dm ³ , hl, yd ³ , ft ³ , in ³ , US gallon, Imp. gallon, bushel, barrel, barrel liquid
volume flow	m ³ /s, m ³ /min, m ³ /h, m ³ /d, l/s, l/min, l/h, l/d, Ml/d, ft ³ /s, ft ³ /min, ft ³ /h, ft ³ /d, US gallon/s, US gallon/min, US gallon/h, US gallon/d, bbl/s, bbl/min, bbl/h, bbl/d
Mass flow	g/s, g/min, g/h, g/d, kg/s, kg/min, kg/h, kg/d, t/s, t/min, t/h, t/d, lb/s, lb/min, lb/h, lb/d, STon/s, STon/min, STon/h, STon/d, LTon/s, LTon/min, LTon/h, LTon/d
Total mass flow	t, kg, g, lb, oz, LTon, STon
Temperature	K, °C, °F, °R
Miscellaneous	%

EU Declaration of Conformity
 EU-Konformitätserklärung
 EU-Déclaration de Conformité



No. A5E31624957A/012

Manufacturer: Siemens AG
 Hersteller:
 Fabricant:
 Address: DE-76181 Karlsruhe
 Anschrift:
 Adresse:

Product description: **Pressure transmitter / Druckmeßumformer**
 Produktbezeichnung: **SITRANS P DS III, SITRANS P410**
 Identificateur: Type / Typ
 7MF4a33-xxfxx-xbxx-Zcde a = 0,1,2,3,4,5,6 b = A,B,D,E,P,R,S cde = xxx
 7MF4a34-xxfxx-xbxx-Zcde a = 0,1,2,3,4,5,6 b = A,B,D,E,P,R,S cde = xxx
 7MF4a35-xxfxx-xbxx-Zcde a = 0,1,2,3,4,5,6 b = A,B,D,E,P,R,S cde = xxx
 a, b, c, d, e, f: see tables annex A / siehe Tabellen im Anhang A

The product described above in the form as delivered is in conformity with the provisions of the following European Directives:

Das bezeichnete Produkt stimmt in der von uns in Verkehr gebrachten Ausführung mit den Vorschriften folgender Europäischer Richtlinien überein:

Le produit mentionné ci-dessus, tel qu'il est livré, est conforme aux dispositions des Directives Européennes suivantes :

- | | |
|--------------------|---|
| 2014/30/EU
EMC | Directive of the European Parliament and of the Council on the harmonisation of the laws of the Member States relating to electromagnetic compatibility
<i>Richtlinie des Europäischen Parlaments und des Rates zur Harmonisierung der Rechtsvorschriften der Mitgliedstaaten über die elektromagnetische Verträglichkeit</i>
<i>Directive du parlement Européen et du conseil relative à l'harmonisation des législations des États membres concernant la compatibilité électromagnétique</i> |
| 2014/34/EU
ATEX | Directive of the European Parliament and the Council on the harmonisation of the laws of the Member States relating to equipment and protective systems intended for use in potentially explosive atmospheres
<i>Richtlinie des Europäischen Parlaments und des Rates zur Harmonisierung der Rechtsvorschriften der Mitgliedstaaten für Geräte und Schutzsysteme zur bestimmungsgemäßen Verwendung in explosionsgefährdeten Bereichen</i>
<i>Directive du parlement Européen et du conseil relative à l'harmonisation des législations des États membres concernant les appareils et les systèmes de protection destinés à être utilisés en atmosphères explosibles</i> |
| 2014/68/EU
PED | Directive of the European Parliament and of the Council on the harmonisation of the laws of the Member States relating to the making available on the market of pressure equipment
<i>Richtlinie des Europäischen Parlaments und des Rates zur Harmonisierung der Rechtsvorschriften der Mitgliedstaaten über die Bereitstellung von Druckgeräten auf dem Markt</i>
<i>Directive du parlement Européen et du conseil relative à l'harmonisation des législations des États membres concernant la mise à disposition sur le marché des équipements sous pression</i> |
| 2011/65/EU
RoHS | Directive of the European Parliament and the Council on the restriction of the use of certain hazardous substances in electrical and electronic equipment.
<i>Richtlinie des Europäischen Parlaments und des Rates zur Beschränkung der Verwendung bestimmter gefährlicher Stoffe in Elektro- und Elektronikgeräten</i>
<i>Directive du parlement Européen et du conseil relative à la limitation de l'utilisation de certaines substances dangereuses dans les équipements électriques et électroniques</i> |

Annex A is integral part of this declaration.
 Anhang A ist integraler Bestandteil dieser Erklärung.
 L'annexe A fait partie intégrante de la présente déclaration

This declaration certifies the conformity to the specified directives but contains no assurance of properties.
 The safety documentation accompanying the product shall be considered in detail.
 Diese Erklärung bescheinigt die Übereinstimmung mit den genannten Richtlinien, ist jedoch keine Beschaffenheits- oder Haltbarkeitsgarantie nach §443 BGB.
 Die Sicherheitshinweise der mitgelieferten Produktdokumentation sind zu beachten.
 La présente déclaration atteste la conformité aux Directives citées. Elle n'est pas assimilable à un descriptif justifiant certaines propriétés.
 La documentation relative à la sécurité accompagnant le produit doit être examiné en détail.

Siemens Aktiengesellschaft: Chairman of the Supervisory Board: Jim Hagemann Snabe; Managing Board: Joe Kaeser, Chairman, President and Chief Executive Officer; Roland Busch, Lisa Davis, Klaus Helmrich, Janina Kugel, Cedrik Neike, Michael Sen, Ralf P. Thomas; Registered offices: Berlin and Munich, Germany; Commercial registries: Berlin Charlottenburg, HRB 12300, Munich, HRB 6684; WEEE-Reg.-No. DE 23691322

EU Declaration of Conformity EU-Konformitätserklärung EU-Déclaration de Conformité

No. A5E31624957A/012

Karlsruhe, 17.04.2018
Siemens Aktiengesellschaft

Volker Rissland,

Research & Development / *Entwicklung / Développement*
(Name, function / *Name, Funktion, / Nom, fonction*)

Signature / Unterschrift / Signature

Jürgen Pflaum,

Quality / *Qualität / Qualité*
(Name, function / *Name, Funktion, / Nom, fonction*)

Signature / Unterschrift / Signature

Annex A is integral part of this declaration.
Anhang A ist integraler Bestandteil dieser Erklärung.
L'annexe A fait partie intégrante de la présente déclaration

This declaration certifies the conformity to the specified directives but contains no assurance of properties.
The safety documentation accompanying the product shall be considered in detail.
Diese Erklärung bescheinigt die Übereinstimmung mit den genannten Richtlinien, ist jedoch keine Beschaffenheits- oder Haltbarkeitsgarantie nach §443 BGB.
Die Sicherheitshinweise der mitgelieferten Produktdokumentation sind zu beachten.
La présente déclaration atteste la conformité aux Directives citées. Elle n'est pas assimilable à un descriptif justifiant certaines propriétés.
La documentation relative à la sécurité accompagnant le produit doit être examiné en détail.

Siemens Aktiengesellschaft: Chairman of the Supervisory Board: Jim Hagemann Snaube; Managing Board: Joe Kaeser, Chairman, President and Chief Executive Officer; Roland Busch, Lisa Davis, Klaus Helmrich, Janina Kugel, Cedrik Neike, Michael Sen, Ralf P. Thomas; Registered offices: Berlin and Munich, Germany; Commercial registries: Berlin Charlottenburg, HRB 12300, Munich, HRB 6684; WEEE-Reg.-No. DE 23691322

Annex A to the EU Declaration of Conformity Anhang A zur EU-Konformitätserklärung Annexe A de la Déclaration de conformité

No. A5E31624957A/012

Product description: **Pressure transmitter / Druckmeßumformer**
 Produktbezeichnung: **SITRANS P DS III, SITRANS P410**
 Identificateur: **Type / Typ**
 7MF4a33-xxfxx-xbxx-Zcde a = 0,1,2,3,4,5,6 b = A,B,D,E,P,R,S cde = xxx
 7MF4a34-xxfxx-xbxx-Zcde a = 0,1,2,3,4,5,6 b = A,B,D,E,P,R,S cde = xxx
 7MF4a35-xxfxx-xbxx-Zcde a = 0,1,2,3,4,5,6 b = A,B,D,E,P,R,S cde = xxx
 a, b, c, d, e, f: see tables annex A / siehe Tabellen im Anhang A

Conformity to the Directives indicated on page 1 is assured through the application of the following standards (depending on versions):

Die Konformität mit den auf Blatt 1 angeführten Richtlinien wird nachgewiesen durch die Einhaltung folgender Normen (variantenabhängig):

La conformité aux Directives indiquées sur la page 1 est garantie par l'application des normes suivantes (selon les versions):

Directive Richtlinie Directive	Standard / Reference number Norm / Referenznummer Norme / référence	Edition Ausgabe datum Edition	b = A cde ≠ E01 a =	b = B cde ≠ E01 a =	b = B cde = E01 a =	b = D cde ≠ E01 a =	b = P cde ≠ E01,C41 a =	b = R cde ≠ E01,C41 a =	b = E cde ≠ E01 a =	b = S cde ≠ E01,C41 a =	f =
2014/30/EU	EN 61326-1*	2013	0,1,2,3,4,5,6	0,1,2,3,4,5,6	0,1,2,3,4,5,6	0,1,2,3,4,5,6	0,2,3,4,5,6	0,2,3,4,5,6	0,1,2,3,4,5,6	0,1,2,3,4,5,6	A,B,C,E,H,L
2014/30/EU	EN 61326-2-5****	2013	0,1,2,3,4,5,6	0,1,2,3,4,5,6	0,1,2,3,4,5,6	0,1,2,3,4,5,6	0,2,3,4,5,6	0,2,3,4,5,6	0,1,2,3,4,5,6	0,1,2,3,4,5,6	A,B,C,E,H,L
2014/30/EU	EN 55011	2009/ A1:2010	0,1,2,3,4,5,6	0,1,2,3,4,5,6	0,1,2,3,4,5,6	0,1,2,3,4,5,6	0,2,3,4,5,6	0,2,3,4,5,6	0,1,2,3,4,5,6	0,1,2,3,4,5,6	A,B,C,E,H,L
2014/34/EU	EN 60079-1 (Note 1)	2014				0,1,2,3,4,5,6	0,2,3,4,5,6	0,2,3,4,5,6			A,B,C,E,H,L
2014/34/EU	EN 60079-15	2010							0,1,2,3,4,5,6		A,B,C,E,H,L
2014/34/EU	EN 60079-0 (Note 1)	2012/ A11:2013		0,1,2,3,4,5,6	0,1,2,3,4,5,6	0,1,2,3,4,5,6	0,2,3,4,5,6	0,2,3,4,5,6	0,1,2,3,4,5,6	0,1,2,3,4,5,6	A,B,C,E,H,L
2014/34/EU	EN 60079-11	2012		0,1,2,3,4,5,6			0,2,3,4,5,6	0,2,3,4,5,6		0,1,2,3,4,5,6	A,B,C,E,H,L
2014/34/EU	EN 60079-26 (Note 1)	2015		0,1,2,3,4,5,6		0,1,2,3,4,5,6	0,2,3,4,5,6	0,2,3,4,5,6		0,1,2,3,4,5,6	A,B,C,E,H,L
2014/34/EU	EN 60079-31	2014			0,1,2,3,4,5,6			0,2,3,4,5,6			A,B,C,E,H,L
2014/68/EU Gas 1 SEP	AD-2000 Merkblätter (A4)	2000/ 2003	0,1,2,3,4,6	0,1,2,3,4,6	0,1,2,3,4,6	0,1,2,3,4,6	0,2,3,4,6	0,2,3,4,6	0,1,2,3,4,6	0,1,2,3,4,6	A,B,C
2014/68/EU Gas 1 Mod.H	AD-2000 Merkblätter (A4)	2000/ 2006	5	5	5	5	5	5	5	5	A,B,C
2014/68/EU Gas 1 SEP	EN 61010-1**	2010	0	0	0	0	0	0	0	0	A,B,C,E,H,L
2014/68/EU Gas 2 SEP	EN 61010-1***	2010	5								A,B,C,E,H,L
2014/68/EU Gas 1 SEP	EN 61010-1****	2010	0,1,2,3,4,5,6	0,1,2,3,4,5,6	0,1,2,3,4,5,6	0,1,2,3,4,5,6	0,2,3,4,5,6	0,2,3,4,5,6	0,1,2,3,4,5,6	0,1,2,3,4,5,6	A,B,C,E,H,L

Note 1: The manufacturer declares that this product complies with the requirements of the new editions of the standards. The changes of the new editions have been checked and do not affect this product.

- * all environments included / beinhaltet alle Umgebungen / dans tout type d'environnement
- ** only Measuring span / nur Messspanne 700 bar (7MF40xx-xJxxx)
- *** only / nur Z-Option D56 PN500
- **** only / nur SITRANS P DS III-PA-FF, SITRANS P410-PA-FF (7MF4a34-xxfxx-xbxx-Zcde and / und 7MF4a35-xxfxx-xbxx-Zcde)
- ***** only / nur SITRANS P DS III / SITRANS P410 (7MF4a3x-xxfxx-xbxx-Zcde, cde =Y99)

EC-type examination certificate EG-Baumusterprüfbescheinigung Certificat évaluation de type	Marking Kennzeichnung Marquage	7MF4a33 b = /cde =	7MF4a34 b = /cde =	7MF4a35 b = /cde =	7MF4a3x a =
PTB 13 ATEX 2007 X	II 1/2 G	B, E	B, E	B, E	
PTB 99 ATEX 1160	II 1/2 G	D	D	D	
PTB 01 ATEX 2055	II 1/2 G II 1 D	P, R, S	P, R, S	P, R, S	
DMT 02 ATEX E 063	II 1 D	B / E01	B / E01	B / E01	
07/202/1201/Z/0157/17/D/0111					5

Inspection / Surveillance:
Kontrolle / Überwachung:
Contrôle / Supervision:

Directive Richtlinie Directive	Notified Body Product Quality Assurance Benannte Stelle Qualitätssicherung Produktion Organisme notifié	No.:
2014/34/EU	ATEX Sira Certification Service, CSA Group Testing UK Ltd – Unit 6, Hawarden Industrial Park, Hawarden, Deeside, CH5 3US, United Kingdom	0518
2014/68/EU	PED TÜV Nord Systems GmbH & Co. KG, Gr. Bahnstr. 31 D-22525 Hamburg	0045