

Pressure Measurement

Transmitters for applications with advanced requirements (Advanced)

SITRANS P320/P420

Technical description

1

Overview



SITRANS P320/P420 pressure transmitters are digital pressure transmitters featuring extensive user-friendliness and high accuracy. The parameter assignment is performed using input buttons or the HART interface.

The comprehensive functionality makes for precise adjustment of the pressure transmitter to the requirements of the plant. Operation is very user-friendly in spite of the numerous setting options.

Due to their advanced diagnostic functionalities according to NAMUR NE107, the SITRANS P320/P420 pressure transmitters are very suitable for use in chemical plants. Thanks to the advanced diagnostic functions and the process value storage, the SITRANS P420 is "Ready for Digitalization".

The "Remote Safety Handling" function saves customers significant amounts of time and money, because the SIL function can be switched on and validated remotely via SIMATIC PDM. This eliminates travel times and on-site operation via the local display or keyboard.

Parameter assignment using the HART protocol is very easy and quick thanks to the innovative EDD with integrated Quick Start wizard.

The transmitters can be equipped with various types of remote seals for special applications such as the measurement of highly viscous substances.

SITRANS P320/P420 pressure transmitters are available in various versions for measuring:

- Gauge pressure
- Absolute pressure
- Differential pressure
- Level
- Volume flow
- Mass flow

Benefits

- Diagnostic functions in accordance with NAMUR recommendation NE107
- SIL devices developed according to IEC 61508
- SIL validation on the device or remotely with SIMATIC PDM
- Reduction of internal inductance for Ex applications to LI = 0
- Step response time for pressure type T63 = 105 ms and for differential pressure type 135 ms.
- Minimal conformity error
- Very low temperature influence
- Very good long-term stability
- High quality and service life
- High reliability even under extreme chemical and mechanical loads
- For corrosive and non-corrosive gases, vapors and liquids
- Extensive diagnostics and simulation functions
- Separate replacement of measuring cell and electronics without recalibration
- Wetted parts made of high-grade materials (e.g., stainless steel, alloy, gold, Monel, tantalum)
- Infinitely adjustable spans from 0.01 bar to 700 bar (0.15 psi to 10153 psi)
- Convenient parameterization over 4 input buttons and HART interface

Application

SITRANS P320/P420 pressure transmitters can be used in industrial areas with extreme chemical and mechanical loads.

The pressure transmitters can be used in zone 1 or zone 0 with the corresponding Ex approval.

The transmitters can be equipped with various designs of remote seals for special applications such as the measurement of highly viscous substances.

The pressure transmitter can be operated locally over 4 input buttons or programmed externally over HART interface.

Pressure transmitter for gauge pressure

Measured variable:

- Gauge pressure of corrosive and non-corrosive gases, vapors and liquids.

Span (infinitely adjustable)

- For SITRANS P320/P420 with HART: 0.01 bar to 700 bar (0.15 psi to 10153 psi)

There are two series:

- Gauge pressure series
- Differential pressure series

Pressure transmitters for absolute pressure

Measured variable:

- Absolute pressure of corrosive and non-corrosive gases, vapors and liquids.

Span (infinitely adjustable)

- For SITRANS P320/P420 with HART: 8.3 mbar a to 100 bar a (0.12 to 1450 psi a)

There are two series:

- Gauge pressure series
- Differential pressure series

Pressure transmitters for differential pressure and flow

Measured variables:

- Differential pressure
- Small positive or negative overpressure
- Flow $q \sim \sqrt{\Delta p}$ (together with a primary differential pressure transducer (see section "Flow meters"))

Span (infinitely adjustable)

- For SITRANS P320/P420 with HART: 1 mbar to 30 bar (0.0145 to 435 psi)

Pressure transmitters for level

Measured variable:

- Level of corrosive and non-corrosive liquids in open and closed vessels.

Span (infinitely adjustable)

- For SITRANS P320/P420 with HART: 25 mbar to 5 bar (0.363 to 72.5 psi)

Type of the mounting flange:

- EN 1092-1 flanges
- ASME B16.5 flanges
- J.I.S. flanges
- Diverse range of sealing surface forms available

Design

Depending on the customer-specific order, the device comprises different parts.

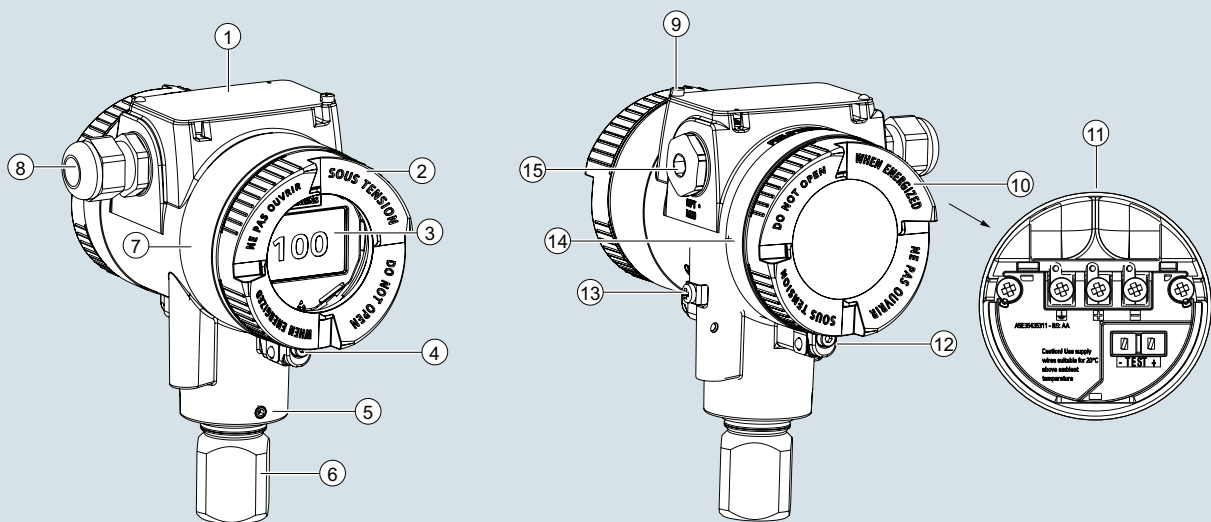

- ① Cover over buttons and nameplate with general information
- ② Cover (front), optionally with inspection window
- ③ Display (optional)
- ④ Safety catch (front)
- ⑤ Retaining screw for rotation of the enclosure
- ⑥ Process connection
- ⑦ Nameplate with approval information
- ⑧ Cable inlet, optionally with cable gland

- ⑨ Screw for the cover over the buttons
- ⑩ Cover (rear) for electrical terminal compartment
- ⑪ Electrical terminal compartment
- ⑫ Safety catch (back)
- ⑬ Ground terminal
- ⑭ Nameplate with information on the remote seal
- ⑮ Blanking plug

Device front view

- The electronics enclosure is made of die cast aluminum or precision cast stainless steel.
- The housing has a removable circular cover at the front and the back.
- Depending on the device version, the front cover (2) may be designed as an inspection window.
- The cable inlet (8) to the electrical terminal compartment is at the side; either the left or right-hand one can be used. The unused opening is closed with a blanking plug (15).
- The ground terminal (13) is located on the side.

- The electrical terminal compartment (11) for the auxiliary power and shield is accessible when you remove the back cover (10).
- The measuring cell with process connection (6) is located in the bottom part of the enclosure. The measuring cell is prevented from rotating by a locking screw (5).
- Thanks to the modular design of the pressure transmitter, the measuring cell and application electronics or terminal compartment can be replaced if required.
- The cover over buttons (1), under which there are 4 buttons, is located on the upper face of the enclosure. The nameplate with general information is located on the cover over the buttons.

Pressure Measurement

Transmitters for applications with advanced requirements (Advanced)
SITRANS P320/P420

1

Technical description

Nameplates

Nameplate

The nameplate with the article no. and other important information, such as design details and technical data, is located on the cover over the buttons.

SIEMENS

SITRANS P320
Transmitter for pressure
7MF0440-1ML02-5BF0-Z
B11+E20
F.-Nr. XXXXXXXXXX

Vh: DC 10.5 ... 45 V (non IS) 4 ... 20 mA HART
Mat.: Connec. Diaphr.. O-ring Filling
1.4404 FPM (FKM) Silicone oil
Min./Max. Measuring span : 16 mbar/1600 mbar
Rated pressure : PN 160

Type of protection IP66
PED:SEP FW: 00.02.04 HW: 00.00.01

Siemens AG, DE-76181 Karlsruhe
Made in France

① Article No.
② Serial number
③ Materials, connection, diaphragm, O-ring, oil
④ Minimum/maximum measuring span
⑤ Nominal pressure
⑥ Degree of protection
⑦ Conformity with country-specific directives
⑧ QR code to mobile website with device-specific information

Nameplate with approval information

The nameplate with approval information is located on the front of the enclosure.

II 1/2 G Ex ia IIC T4/T5/T6 Ga
VH: DC 10.5 ... 45 V output: 4 ... 20 mA
from certified intrinsically safe power source
VI ≤ 30 V ; II ≤ 100 mA ; PI ≤ 0.75 W
LI ≤ 0.4 mH ; CI ≤ 6 nF

PTB XX ATEX XXXX
Note test certificate I
-40°C ≤ Ta ≤ +60°C (T5) / +85°C (T4)

II 1/2 G	Ex ia	IIC	T4/T5/T6	Ga
①	②	③	④	⑤

① Characteristics of the hazardous area
② Type of protection
③ Group (gas, dust)
④ Maximum surface temperature (temperature class)
⑤ Device protection level

Measuring point label

The measuring point label is located under the front cover.



Nameplate with information on the remote seals

The nameplate with information on the remote seals is located on the back of the enclosure.

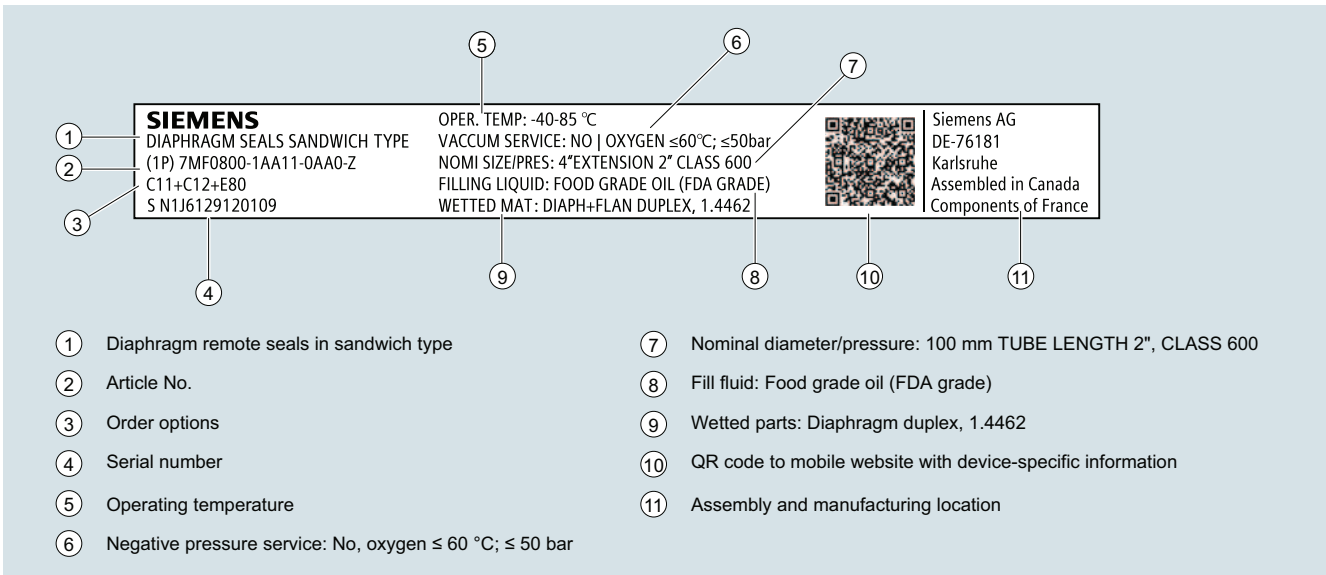

- ① Diaphragm remote seals in sandwich type
- ② Article No.
- ③ Order options
- ④ Serial number
- ⑤ Operating temperature
- ⑥ Negative pressure service: No, oxygen ≤ 60 °C; ≤ 50 bar
- ⑦ Nominal diameter/pressure: 100 mm TUBE LENGTH 2", CLASS 600
- ⑧ Fill fluid: Food grade oil (FDA grade)
- ⑨ Wetted parts: Diaphragm duplex, 1.4462
- ⑩ QR code to mobile website with device-specific information
- ⑪ Assembly and manufacturing location

Pressure Measurement

Transmitters for applications with advanced requirements (Advanced)

SITRANS P320/P420

Technical description

Function

Adjustable parameters and diagnostics

SITRANS P320/P420 with HART communication

Parameters	Input buttons	SITRANS P320	SITRANS P420
Application, measurement type	x	x	x
Adjusting start of scale value/full scale value	x	x	x
Setting start of scale value/full scale value	x	x	x
Electrical damping	x	x	x
Zero adjustment	x	x	x
Fault current	x	x	x
Saturation limits	x	x	x
Scaling of the display	x	x	x
Characteristic selection	x	x	x
Temperature unit	x	x	x
Key lock	x	x	x
Change user pin	x	x	x
Functional safety	x	x	x
Loop test	x	x	x
Start view	x	x	x
Pressure reference	x	x	x
Reset	x	x	x
Diagnostics and trend log			
Min/Max pointer		x	x
Limit monitoring			2
Event counter (overflow/underflow)			2
Trend log			2, max. 1 500 values

Available physical units of display for SITRANS P320/P420

Physical variable	Physical dimensions
Pressure (setting can also be made in the factory)	Pa, MPa, kPa, hPa, bar, mbar, psi, g/cm ² , kg/cm ² , kgf/cm ² , inH ₂ O, inH ₂ O (4 °C), ftH ₂ O, mmH ₂ O, mmH ₂ O (4 °C), mH ₂ O (4 °C), mmHg, inHg, atm, torr
Level (height data)	m, cm, mm, ft, in
Volumes (fill level)	m ³ , l, hl, in ³ , ft ³ , yd ³ , gal, gal (UK), bu, bbl, bbl (US), SCF, Nm ³ , NI
Volume (flow)	m ³ /sec, m ³ /h, m ³ /d, l/sec, l/min, l/h, Ml/d, ft ³ /sec, ft ³ /h, ft ³ /d, SCF/min, SCF/h, NI/h, Nm ³ /hgal/sec, gal/min, gal/h, gal/d, Mgal/d, gal (UK)/sec, gal (UK)/min, gal (UK)/h, gal (UK)/d, bbl/sec, bbl/min, bbl/h, bbl/d,
Mass (flow)	Kg/sec, kg/min, kg/h, kg/d, g/sec, g/min, g/h, t/min, t/h, t/d, lb/sec, lb/min, lb/h, lb/d, ton/min, ton/h, ton/d, ton (UK)/h, ton (UK)/d
Temperature	°C, °F
Miscellaneous	%, mA, free text max. 12 characters

For more device information and technical specifications, refer to the individual device versions.

EU Declaration of Conformity
 EU-Konformitätserklärung
 EU-Déclaration de Conformité



No. A5E44320812A/002

Manufacturer: Siemens AG
 Hersteller:
 Fabricant:
 Address: DE-76181 Karlsruhe
 Anschrift:
 Adresse:

Product description: **Pressure transmitter / Druckmeßumformer**
 Produktbezeichnung: **SITRANS P320, SITRANS P420**
 Identificateur: Type / Typ
 7MF03a0-xxxxx-5bxx-Zcde
 7MF04a0-xxxxx-5bxx-Zcde

The product described above in the form as delivered is in conformity with the provisions of the following European Directives:

Das bezeichnete Produkt stimmt in der von uns in Verkehr gebrachten Ausführung mit den Vorschriften folgender Europäischer Richtlinien überein:

Le produit mentionné ci-dessus, tel qu'il est livré, est conforme aux dispositions des Directives Européennes suivantes :

- | | |
|--------------------|---|
| 2014/30/EU
EMC | Directive of the European Parliament and of the Council on the harmonisation of the laws of the Member States relating to electromagnetic compatibility
<i>Richtlinie des Europäischen Parlaments und des Rates zur Harmonisierung der Rechtsvorschriften der Mitgliedstaaten über die elektromagnetische Verträglichkeit</i>
<i>Directive du parlement Européen et du conseil relative à l'harmonisation des législations des États membres concernant la compatibilité électromagnétique</i> |
| 2014/34/EU
ATEX | Directive of the European Parliament and the Council on the harmonisation of the laws of the Member States relating to equipment and protective systems intended for use in potentially explosive atmospheres
<i>Richtlinie des Europäischen Parlaments und des Rates zur Harmonisierung der Rechtsvorschriften der Mitgliedstaaten für Geräte und Schutzsysteme zur bestimmungsgemäßen Verwendung in explosionsgefährdeten Bereichen</i>
<i>Directive du parlement Européen et du conseil relative à l'harmonisation des législations des États membres concernant les appareils et les systèmes de protection destinés à être utilisés en atmosphères explosibles</i> |
| 2014/68/EU
PED | Directive of the European Parliament and of the Council on the harmonisation of the laws of the Member States relating to the making available on the market of pressure equipment
<i>Richtlinie des Europäischen Parlaments und des Rates zur Harmonisierung der Rechtsvorschriften der Mitgliedstaaten über die Bereitstellung von Druckgeräten auf dem Markt</i>
<i>Directive du parlement Européen et du conseil relative à l'harmonisation des législations des États membres concernant la mise à disposition sur le marché des équipements sous pression</i> |
| 2011/65/EU
RoHS | Directive of the European Parliament and the Council on the restriction of the use of certain hazardous substances in electrical and electronic equipment.
<i>Richtlinie des Europäischen Parlaments und des Rates zur Beschränkung der Verwendung bestimmter gefährlicher Stoffe in Elektro- und Elektronikgeräten</i>
<i>Directive du parlement Européen et du conseil relative à la limitation de l'utilisation de certaines substances dangereuses dans les équipements électriques et électroniques</i> |

Annex A is integral part of this declaration.
Anhang A ist integraler Bestandteil dieser Erklärung.
L'annexe A fait partie intégrante de la présente déclaration

This declaration certifies the conformity to the specified directives but contains no assurance of properties.
 The safety documentation accompanying the product shall be considered in detail.
Diese Erklärung bescheinigt die Übereinstimmung mit den genannten Richtlinien, ist jedoch keine Beschaffenheits- oder Haltbarkeitsgarantie nach §443 BGB.
Die Sicherheitshinweise der mitgelieferten Produktdokumentation sind zu beachten.
La présente déclaration atteste la conformité aux Directives citées. Elle n'est pas assimilable à un descriptif justifiant certaines propriétés.
La documentation relative à la sécurité accompagnant le produit doit être examiné en détail.

Siemens Aktiengesellschaft: Chairman of the Supervisory Board: Jim Hagemann Snabe; Managing Board: Joe Kaeser, Chairman, President and Chief Executive Officer; Roland Busch, Lisa Davis, Klaus Helmrich, Janina Kugel, Cedrik Neike, Michael Sen, Ralf P. Thomas; Registered offices: Berlin and Munich, Germany; Commercial registries: Berlin Charlottenburg, HRB 12300, Munich, HRB 6684; WEEE-Reg.-No. DE 23691322

EU Declaration of Conformity *EU-Konformitätserklärung* *EU-Déclaration de Conformité*

No. A5E44320812A/002

Karlsruhe, 20.09.2018
Siemens Aktiengesellschaft

Volker Rissland,
Research & Development / *Entwicklung / Développement*
(Name, function / *Name, Funktion, / Nom, fonction*)



Signature / *Unterschrift / Signature*

Jürgen Pflaum,
Quality / *Qualität / Qualité*
(Name, function / *Name, Funktion, / Nom, fonction*)



Signature / *Unterschrift / Signature*

Annex A is integral part of this declaration.
Anhang A ist integraler Bestandteil dieser Erklärung.
L'annexe A fait partie intégrante de la présente déclaration

This declaration certifies the conformity to the specified directives but contains no assurance of properties.
The safety documentation accompanying the product shall be considered in detail.
Diese Erklärung bescheinigt die Übereinstimmung mit den genannten Richtlinien, ist jedoch keine Beschaffenheits- oder Haltbarkeitsgarantie nach §443 BGB.
Die Sicherheitshinweise der mitgelieferten Produktdokumentation sind zu beachten.
La présente déclaration atteste la conformité aux Directives citées. Elle n'est pas assimilable à un descriptif justifiant certaines propriétés.
La documentation relative à la sécurité accompagnant le produit doit être examiné en détail.

Siemens Aktiengesellschaft: Chairman of the Supervisory Board: Jim Hagemann Snaube; Managing Board: Joe Kaeser, Chairman, President and Chief Executive Officer; Roland Busch, Lisa Davis, Klaus Helmrich, Janina Kugel, Cedrik Neike, Michael Sen, Ralf P. Thomas; Registered offices: Berlin and Munich, Germany; Commercial registries: Berlin Charlottenburg, HRB 12300, Munich, HRB 6684; WEEE-Reg.-No. DE 23691322

Annex A to the EU Declaration of Conformity
Anhang A zur EU-Konformitätserklärung
Annexe A de la Déclaration de conformité

No. A5E44320812A/002

Product description: Pressure transmitter / Druckmeßumformer
Produktbezeichnung: SITRANS P320, SITRANS P420
Identificateur: Type / Typ
 7MF03a0-xxxxx-5bxx-Zcde
 7MF04a0-xxxxx-5bxx-Zcde

Conformity to the Directives indicated on page 1 is assured through the application of the following standards (depending on versions):

Die Konformität mit den auf Blatt 1 angeführten Richtlinien wird nachgewiesen durch die Einhaltung folgender Normen (variantenabhängig):

La conformité aux Directives indiquées sur la page 1 est garantie par l'application des normes suivantes (selon les versions):

Directive Richtlinie Directive	Standard / Reference number Norm / Referenznummer Norme / référence	Edition Ausgabedatum Edition	a=	b=	cde=
2014/30/EU	EN 61326-1 *	2013	0,1,2,3,4,5,6	A,B,C,D,L,M,S,T	xxx
2014/30/EU	EN 61326-2-3 *	2013			
2014/30/EU	EN 55011	2009/A1:2010			
2014/34/EU	EN 60079-0	2012/A11:2013			E20, E47
2014/34/EU	EN 60079-1	2014			
2014/34/EU	EN 60079-7	2015			
2014/34/EU	EN 60079-11	2012			
2014/34/EU	EN 60079-26	2015			
2014/34/EU	EN 60079-31	2014			
2014/68/EU Gas 1 Mod.H	AD-2000 Merkblätter (A4)	2000 / 2006	5	A,B,C,D,L,M,S,T	xxx
2014/68/EU Gas 1 SEP	EN 61010-1	2010	0,1,2,3,4,6		

* all environments included / beinhaltet alle Umgebungen / dans tout type d'environnement

Certificates:

Zertifikate:

Certificat:

EC-type examination certificate EG-Baumusterprüfbescheinigung Certificat évaluation de type	Marking Kennzeichnung Marquage
BVS 18 ATEX E 049 X	II 1 G
07/202/1201/Z/0157/17/D/0111	

Inspection / Surveillance:

Kontrolle / Überwachung:

Contrôle / Supervision:

Directive Richtlinie Directive		Notified Body Product Quality Assurance Benannte Stelle Qualitätssicherung Produktion Organisme notifié	No.:
2014/34/EU	ATEX	Sira Certification Service, CSA Group Testing UK Ltd – Unit 6, Hawarden Industrial Park, Hawarden, Deeside, CH5 3US, United Kingdom	0518
2014/68/EU	PED	TÜV Nord Systems GmbH & Co KG. Gr, Bahnstr. 31 D-22525 Hamburg	0045