

# SITRANS F US

*Ultrasonic flowmeter*

*Transmitter type FUS060 HART*

*for use with sensor type SONO 3100,  
SONO 3300 and SONOKIT 1- and 2-tracks*



Technical Documentation (handbooks, instructions, manuals etc.) on the complete product range SITRANS F can be found on the internet/intranet on the following links:

English: <http://www4.ad.siemens.de/WW/view/en/10806951/133300>





Order no.: A5E01204521

SFIDK.PS.029.E5.02



**System overview**  
**SITRANS F US**  
**FUS060 with**  
**SONO 3100,**  
**SONOKIT**  
**and SONO 3300**

This operating manual is for the transmitter part of the flowmeter consisting of sensors type SONO 3100, SONO 3300 and SONOKIT. These sensors have separate operating manuals.

Sensor	Mild steel Standard program	Stainless steel and mild steel Extended program	Retrofit program 1 or 2-tracks
	SONO 3300 	SONO 3100 	SONOKIT 
Size [mm]	DN 50 - DN 300	DN 100 - DN 1200	DN 100 - DN 4000
Connection examples	EN 1092-1 ANSI B 16.5 150 lbs RF ANSI B 16.5 300 lbs RF		None
Pressure [bar]	PN 10, PN 16, PN 40, Class 150, Class 300	PN 10, PN 16, PN 25, PN 40 Class 150, Class 300	Max. PN 40
Media temperature Max. °C (°F)	160 (320)	200 (394)	200 (394)
Transducer	Integrated transducers	SONO 3200 O-ring type Flange type	SONO 3200 O-ring type
Enclosure	IP67	IP68	IP68
Approvals	ATEX	ATEX	ATEX
<b>Transmitter</b>	FUS060 		
<b>Enclosure</b>	IP65 (NEMA 4)		
<b>Mounting</b>	Separate wall mounting		
<b>Accuracy</b>	± 0.5% of actual flow		
<b>Materials</b>	Die-cast aluminium		
<b>Outputs</b>	1 current / HART / Profibus PA 1 frequency/pulse 1 relay		
<b>Display/counter</b>	Alphanumeric: flow, quantity, error, mass flow, sound velocity, etc.		
<b>Language</b>	English, German, French, Spanish		
<b>Approval</b>	ATEX		
<b>Supply voltage</b>	115/230 V AC 24 V AC/DC		

---

## Contents

<b>1</b>	<b>Introduction .....</b>	<b>4</b>
1.1	Preface .....	4
1.2	Introduction .....	4
1.3	Precision measuring system .....	5
1.4	Literature overview .....	5
1.5	System overview .....	5
1.6	Technical data transmitter SITRANS FUS060 .....	6
1.7	Dimensional drawings .....	8
1.8	Measurement .....	9
1.8.1	Principle of measurement .....	9
1.8.2	Measuring principle .....	9
<b>2</b>	<b>General safety instructions .....</b>	<b>10</b>
2.1	Safety notes .....	10
2.2	General notes for the user .....	10
<b>3</b>	<b>Sitrans FUS060 .....</b>	<b>11</b>
3.1	Installing Sitrans FUS060 .....	11
3.2	Installation .....	11
3.2.1	Wall assembly (standard included) .....	11
3.2.2	Pipe assembly (accessory) .....	11
3.3	Connecting the sensor cables to the transmitter .....	12
3.4	Mounting the cables into SITRANS FUS060 connection module .....	12
3.5	Electrical connection of the sensors / transducers .....	13
3.5.1	Electrical connection - transmitter to transducers (1-track) .....	13
3.5.2	Electrical connection - transmitter to transducers (2-tracks) .....	13
3.5.3	Electrical connection - allowed cable radius .....	14
3.6	Rotating the operating and display panel .....	14
3.7	Warning .....	15
<b>4</b>	<b>Start up .....</b>	<b>17</b>
4.1	Electrical data connection - Ex-version .....	17
4.2	Operation (HART communication) .....	18
<b>5</b>	<b>Commissioning .....</b>	<b>19</b>
5.1	Keypad and display lay-out .....	19
5.2	Operating concept of operating and display panel .....	19
5.3	Menu structure (SW version 2.01.07) .....	20
5.4	Disabling or enabling access to settings .....	21
5.5	Operating examples .....	22
5.6	Setting option and factory setting in the display .....	24
<b>6</b>	<b>Device functions and parameters .....</b>	<b>33</b>
6.1	Main menu: Display (menu 1) .....	33
6.2	Main menu: Diagnostics (menu 2) .....	34
6.3	Main menu: Measuring functions (menu 3) .....	35
6.4	Main menu: Device output (menu 4) .....	37
6.5	Main menu: Identification (menu 5) .....	41
6.6	Main menu: Service (menu 6) .....	42
6.7	Main menu: Sensor parameters (menu 7) .....	43
6.8	Procedure for entering data into the SITRANS FUS060 transmitter: .....	47
<b>7</b>	<b>Trouble shooting .....</b>	<b>48</b>
<b>8</b>	<b>Maintenance and repair .....</b>	<b>50</b>
8.1	Technical information on the application .....	51
<b>9</b>	<b>Certificates .....</b>	<b>52</b>

## 1.1 Preface

These instructions contain all the information required to commission and use the SITRANS F US ultrasonic flowmeter transmitter type FUS060 HART with sensor type SONO 3100, SONO 3300, SONOKIT 1- and 2-tracks.

These instructions are intended to assist personnel performing mechanical installation, electrical connection and commissioning of the device, as well as service and maintenance engineers.

---

## 1.2 Introduction

This manual describes only the installation of the FUS060 HART transmitter (with HART interface). The transmitter FUS060 with a sensor (SONO 3100, SONO 3300 or SONOKIT) is designed for measuring the flow velocity of liquids in full pipes. Satisfactory function of the ultrasonic flowmeter depends on a low sound attenuation of the medium and a well-defined and stable flow profile.

The installation of an ultrasonic flowmeter system with transmitter type FUS060 is divided into 5 steps:

1. Selection of the measuring site
2. Installation of the sensor in the pipe (see separate sensor manual)
3. Mechanical installation of the transmitter (e. g. wall mounting)
4. Electrical connection of the transmitter
5. Electrical connection of the sensor transducers to the transmitter

---

**To ensure optimum performance of the measuring equipment it is essential that the following instructions are followed.**

---

Siemens Flow Instruments SITRANS F US ultrasonic flowmeters are designed for measurement of:

- Volume or mass flow rate
- Limit monitoring
- Total volume or mass
- Sound velocity in the media

SITRANS F US ultrasonic flowmeters measure flow in standard volumetric and mass flow units. Measurement is independent of changes in liquid temperature, density, pressure, and conductivity. This ultrasonic flowmeter is designed for use on single phase liquids.



### **Potential Hazards**

Both transmitter and sensor must be grounded for optimal performance.

According to the "Ex-requirements", the 'PE-terminals' on the FUS060 and on the sensors (SONO 3200 transducers or SONO 3300 sensor) must be potential equalised (min. 4 mm<sup>2</sup>).

---

## 1.3 Precision measuring system

The ultrasonic flowmeter is a precision measuring system that is “user friendly”, but must be installed in accordance with the instructions given in these operating instructions.

---

## 1.4 Literature overview

For flow meters based on the FUS060 transmitter various technical literature such as operating instructions and quick start manuals are available on the CD-ROM shipped with the device, or it can be found on the Internet at [www.siemens.com/flowdocumentation](http://www.siemens.com/flowdocumentation), where further information on the SITRANS F flow meter range is also available.

SITRANS F US sensor and transmitter versions have separate operating instructions.

These operating instructions concern only the FUS060 HART transmitter part of the flow meter system. The FUS060 Profibus PA transmitter version and SONO 3100, SONO 3300 or SONOKIT sensors have separate operating instructions.

---

## 1.5 System overview

The SITRANS F US ultrasonic flowmeter systems consist of a sensor and a transmitter. The systems consists of sensor type SONO 3100, SONO 3300 or SONOKIT and the transmitter type FUS060. The following table shows the ultrasonic flowmeter systems with the transmitter type FUS060:

Sensor type	Transmitter	Outputs	Measurement
SONO 3100 DN 100 – DN 1200	FUS060	<ul style="list-style-type: none"><li>• 1 analog with HART</li><li>• 1 frequency-/pulse</li><li>• 1 relay</li></ul>	<ul style="list-style-type: none"><li>• Volume flow rate</li><li>• Total volume</li><li>• Mass flow rate</li><li>• Total mass</li></ul>
SONO 3300 DN 50 – DN 300		or	<ul style="list-style-type: none"><li>• Sound velocity</li><li>• Error indication</li></ul>
SONOKIT DN 100 – DN 4000		<ul style="list-style-type: none"><li>• Profibus PA</li><li>• 1 frequency-/pulse</li></ul>	<ul style="list-style-type: none"><li>• Limit monitoring</li><li>• Ultrasonic Amplitude</li></ul>

These operating instructions is only for the transmitter part of the flowmeter system. The SONO 3100, SONO 3300 or SONOKIT sensors have separate operating instructions.

## 1.6 Technical data - transmitter SITRANS FUS060



<b>Output</b>	
<b>Analog output</b>	
Signal range	4...20 mA active current output. (13.2V<open loop voltage<15.8V)
Upper limit	20...22.5 mA, adjustable
Signal on alarm	3.6 mA, 22 mA or 24 mA
Load	Max 600 ohm for non Ex version Max 330 ohm Ex version.
Only PROFIBUS PA version	Analog output omitted, is replaced by digital PROFIBUS PA interface
<b>Digital output 1</b>	
Active or passive signal, can be configured with positive or negative logic	Active: 24 V DC, $\leq 24$ mA, $R_i = 300 \Omega$ Passive: open collector, 30 V DC, $\leq 200$ mA
For explosion protection ATEX II 2G Ex dem [ia/ib] T6..T3	Passive: open collector, 30 V DC, $\leq 100$ mA
Output function, configurable	<b>Pulse output</b> Adjustable pulse significance $\leq 5000$ pulses/s Adjustable pulse width $\geq 0.1$ ms
	<b>Frequency output</b> $f_{END}$ selectable up to 10 kHz
<b>Error in measurement:</b> (at reference conditions)	
Pulse output	$\leq \pm 0.5\%$ of measured value at 0.5 m/s to 10 m/s or $\leq \pm 0.25 / v$ [m/s]% of measured value at flow $< 0.5$ m/s
Analog output	As pulse output plus $\pm 0.1\% \pm 20 \mu A$
Repeatability	$\leq \pm 0.25\%$ of measured value at 0.5 m/s to 10 m/s
<b>Digital output 2 (Relay)</b>	
Relay, NC or NO contact	Switching capacity max. 5 W Max. 50 V DC, max. DC 200 mA Self-resetting fuse, $R_i = 9 \Omega$
For explosion protection ATEX II 2G Ex dem [ia/ib] IIC T6..T3	Max. 30 V DC, for DC max. 100 mA, for AC max. 50 mA (cf. EC-Type Examination certificate)
Output function, configurable for:	Alarm, flow direction, flow limits, sound velocity limits, ultrasonic-amplitude limits, no function
<b>Communication via analog output 4...20 mA</b>	
PC/laptop (PDM) or HART communicator with SITRANS F flowmeter	
Load	Min. load 230 Ohm
Cable	2-wire shield $\leq 3$ km ( $\leq 1.86$ miles) Multi-core shield $\leq 1.5$ km ( $\leq 0.93$ miles)
Protocol	HART, version 5.1
<b>Electrical isolation</b>	Outputs electrically isolated from power supply and from each other (Output isolation 63 Vac/100 Vdc to ground.)
<b>Ambient temperature</b> (transmitter)	-20...+50 °C (-4...+122 °F)
In potentially explosive atmospheres	Observe temperature class
<b>Storage temperature</b>	-25...+80 °C (-13...+176 °F)
<b>Enclosure rating</b>	IP65
<b>Electromagnetic compatibility</b>	For use in industrial environments
Emission	EN 61000-6-3 (Light industry)
Immunity	EN 61000-6-2 (Industry)
	Use shield cables for the outputs

<b>Design</b>	
Transmitter only as separate version	Transmitter weight: 4.4 kg (9.7 lb) Transmitter is connected to the transducers via 3 ... 120 m (9,8 ... 395 ft) long coaxial cables. For ATEX versions mounted in the Ex zone cable length is restricted to 3m, in order to comply with specification for electrical immunity.
Housing material	Die-cast aluminum, painted
Electrical connection	Cable glands: 2x M20 or 2x ½"-NPT Transducers: 2/4x M16 or 2/4x ½" NPT
<b>Displays and controls</b>	
Display	LCD, two lines with 16 characters each (backlit)
Multi-display: 2 freely-selectable values are displayed simultaneously in two lines	Flow, volume, mass flow, mass, flow velocity, speed of sound, ultrasonic signal information, current, frequency
Operation	4 infrared keys Hierarchical menu prompting with numbering
<b>Power supply</b>	
Supply voltage for standard version	120...230 V AC ± 15% (50/60 Hz) 19...30 V DC/ 21...26 V AC
Supply voltage for Ex version	19...30 V DC/ 21...26 V AC
Power failure	No effect for at least 1 period (> 20 ms)
Power consumption	Approx. 8 VA / 6 W
<b>Reference conditions</b>	
Process temperature	25 °C ± 5 °C (77 °F ± 9 °F)
Ambient temperature	25 °C ± 5 °C (77 °F ± 9 °F)
Installation conditions	Upstream section > 20x DN and downstream section > 5x DN
Warming-up time	30 min.
<b>Certificates and approvals</b>	
	Explosion protection ATEX II 2G Ex dem [ia/ib] IIC T6 for media<85°C T5 for media<100°C T4 media<135°C T3 media<200°C

**Note**

For full performance at 10 KHz frequency on digital output 1, the capacitive load should not exceed 100 nF.

## 1.7 Dimensional drawings

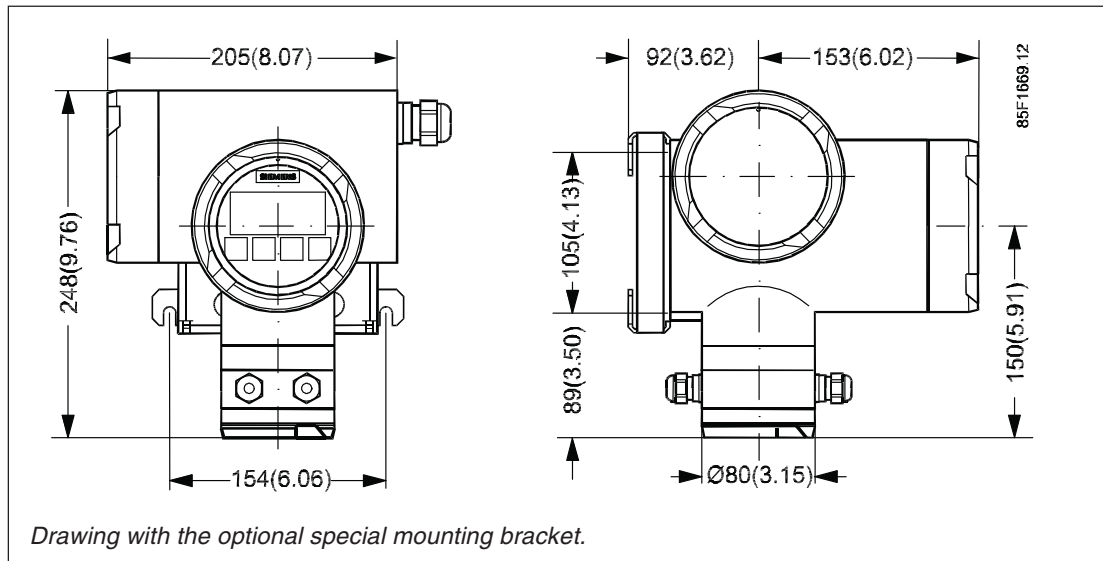
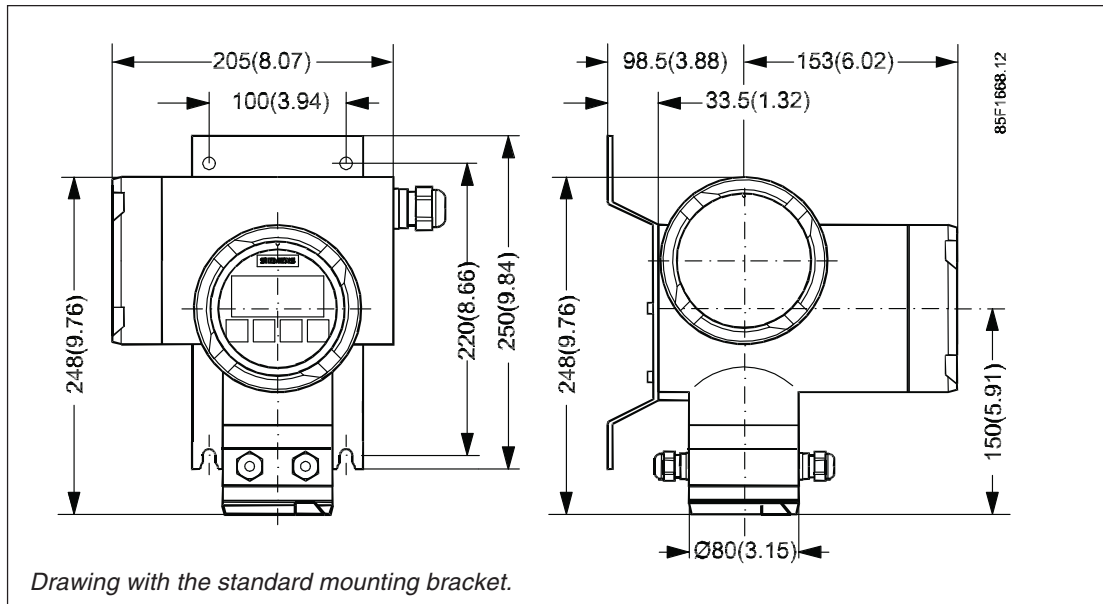



## 1.8 Measurement

### 1.8.1 Principle of measurement

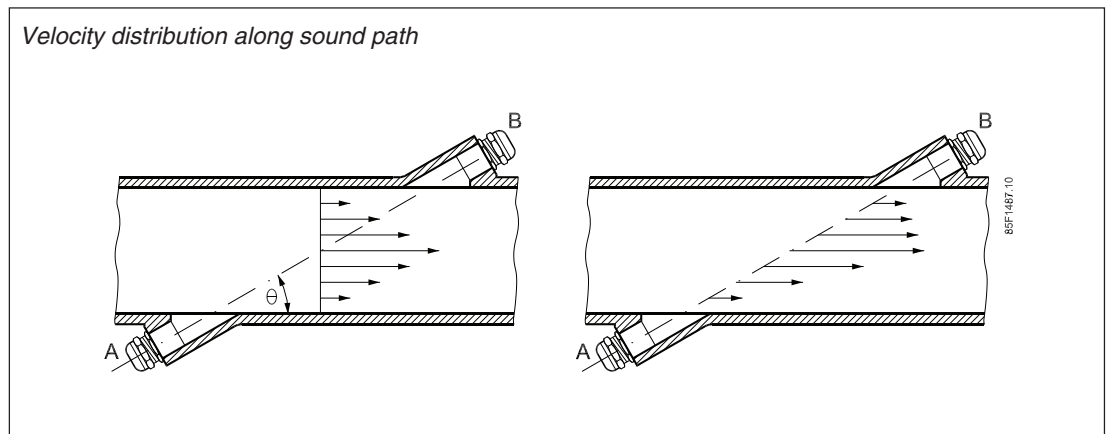

A sound wave travelling in the same direction as the liquid flow arrives at point B from point A in a shorter time than the sound wave travelling against the flow direction (from point B to A). The difference in sound transit time indicates the flow velocity in the pipe. Since delay time is measured at short intervals both in and against flow direction, viscosity and temperature have no influence on measurement accuracy.

### 1.8.2 Measuring principle

In SITRANS F US flowmeters the two ultrasonic transducers are placed at an angle  $\theta$  in relation to the pipe axis. The transducers function as both transmitters and receivers of the ultrasonic signals. Measurement is performed by determining the time it takes the ultrasonic signal to travel with and against the flow. The principle can be expressed as follows:

$$v = K \cdot (t_{B,A} - t_{A,B}) / (t_{B,A} \cdot t_{A,B}) = K \cdot \Delta t / t^2$$

$v$  = Average flow velocity

$t$  = Transit time

$K$  = Proportional flow factor

This measuring principle offers the advantage that it is independent of variations in the actual sound velocity of the liquid, ie independent of temperature. Proportional factor  $K$  is determined by wet calibration ("Wet calibration factor") or "Auto" (SONOKIT only) in case of manual programming of transducer angle, transducer distance, transducer displacement and pipe dimensions.

## 2.1 Safety notes



For safety reasons it is important that the following points, especially those marked with a warning sign, are read and understood before the system is installed:

- Installation, connection, commissioning and service must be carried out by personnel who are qualified and authorized to do so.
- It is very important for any person working with the equipment to read and understand the instructions and directions provided in these instructions and follow instructions and directions before using the equipment.
- Only personnel authorized and trained by the owner of the equipment may operate the equipment.
- Installation personnel must ensure that the measuring system is correctly connected in accordance with the connection diagram in these instructions.
- For applications involving high working pressures or media that can be dangerous to people, surroundings, equipment or other in the event of pipe fracture, Siemens recommends taking precautions such as special placement, shielding or installation of a safety guard or safety valve prior to installation of the sensor.
- Repair and service should be performed by approved Siemens Flow Instruments personnel only.



### Warning

The apparatus is not capable of withstanding the 500V insulation test required by Clause 6.3.12 of EN60079-11. This must be taken into account when installing the apparatus.

---

## 2.2 General notes for the user



These operation instructions describe installation, start-up, operation and servicing of the ultrasonic flowmeter. Of particular importance are warning and information texts. These are separated from the remaining text, specially identified by appropriate pictograms (see examples on the left), and provide valuable tips on how to avoid maloperations.

**Warning** means that death, severe personal injury and/or substantial damage to property can occur if the appropriate safety precautions are not observed.



### Note

is important information on the product itself, the handling of the product or the respective part of the operating instructions to which particular attention should be paid.



### Warning

According to the "Ex-requirements", the PE-terminals on the FUS060 and on the sensors (SONO 3200 transducers or SONO 3100) must be potential equalised (min. 4 mm<sup>2</sup>).

## 3.1 Installing SITRANS FUS060



## 3.2 Installation

### 3.2.1 Wall assembly (standard included)

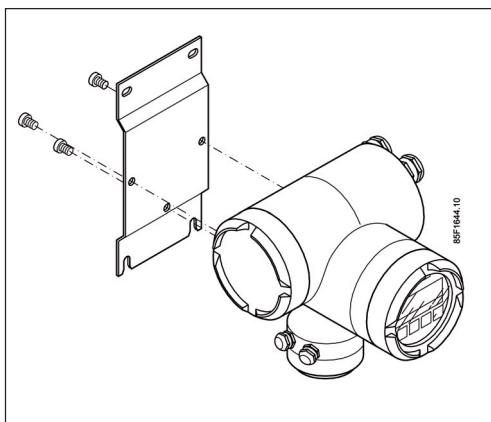

The mounting bracket is suitable for wall assembly only.

For wall assembly the mounting bracket is screwed directly to the back of the transmitter prior to being fixed to the wall.

### 3.2.2 Pipe assembly (accessory)



For mounting on pipes a special mounting bracket can be ordered at Siemens.  
Siemens order no. - please see FI01 catalogue.

### 3.3 Connecting the sensor cables to the transmitter

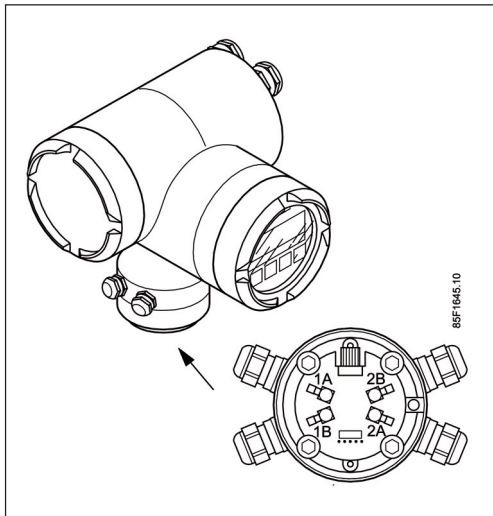

When opening the lid you will have direct access to checking the correct transducer cable connections.

### 3.4 Mounting the cables into SITRANS FUS060 connection module

The SITRANS F US ultrasonic flowmeter system contain 2 or 4 cables in fixed length of 3, 15, 30, 60, 90 or 120 m (9.84 / 49.21 / 98.43 / 196.85 / 295.28 / 393.70 ft).

The cables to be connected to the transducers according to the schematics 3.5.1 or 3.5.2. Check and then enter the cable length in the transmitter. Make sure the cables are equal in length in order to avoid different signal delays in the signal processing.

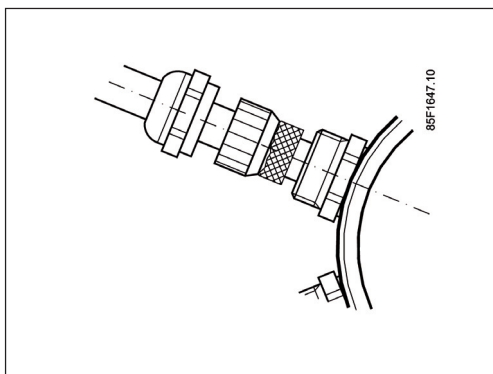

For connection of the 4 cables, just carefully press the cable into the cable glands until the "snap function" **fixes** the cable inside the connection module. Make sure the cable is mounted correctly by smoothly pulling the cable.

Carefully press the appropriate cables into the connection module until fully connected into the plug.

The cable glands are tightened on the threaded bush until the cable is sealed tightly (IP65).

### 3.5 Electrical connection of the sensors / transducers

The connection of the terminal housing of sensor type SONO 3300 is described in the separate sensor operating instructions.

The sensors type SONO 3100 and SONOKIT consist of a sensor pipe and 2 / 4 ultrasonic transducers type SONO 3200. The terminal housing is fastened to the transducer holder by means of a union. Avoid stress on the two inner wires when transferring them into the terminal housing, . The wire without a thimble is connected to position 2. The wire with a thimble is connected to the transducer housing by means of position 3. The inner wire of the transducer coax cable is fastened with the cable lamp into position 4. The transducer cables can be shortened at the respective transducer end (not at the high temperature versions). In this case, the cable length must be corrected in the FUS060 (menu 7).

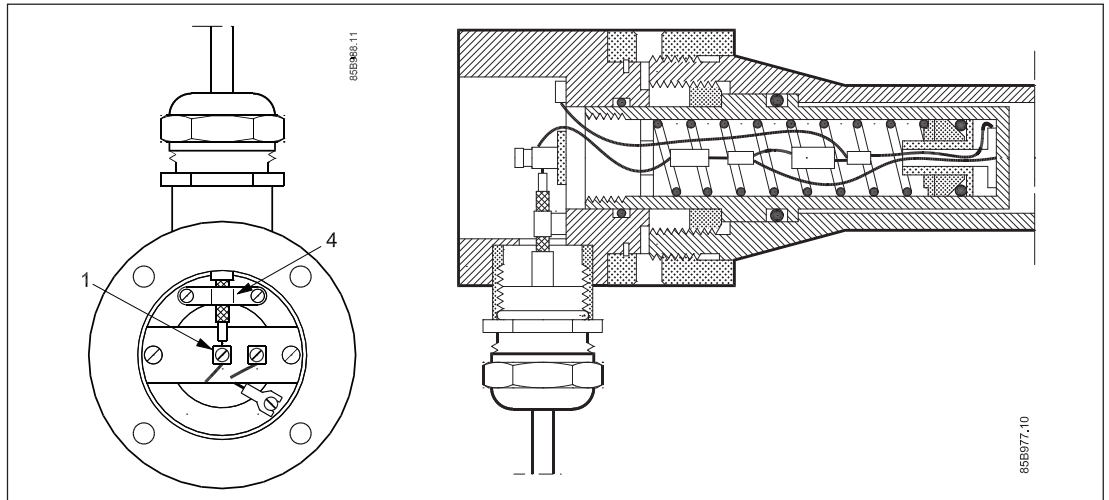

**Note**

When the terminal box is disassembled, the wires (2 and 3) must be loosened from the connection board. It is not necessary to remove the transducer cables (1 and 4).

Support the terminal box while loosening the union. Then remove the terminal box from the transducer holder.



**Warning**

Twisting the terminal box can damage the wires to the crystals.



**Warning**

According to the "Ex-requirements", the 'PE-terminals' on the FUS060 and on the sensors (SONO 3200 transducers or SONO 3300 sensor) must be potential equalised (min. 4 mm<sup>2</sup>).



**Warning**

The PE-terminals should always be connected to solve EMC problems (Ex-Version on non Ex).

#### 3.5.1 Electrical connection - transmitter to transducers (1-track)

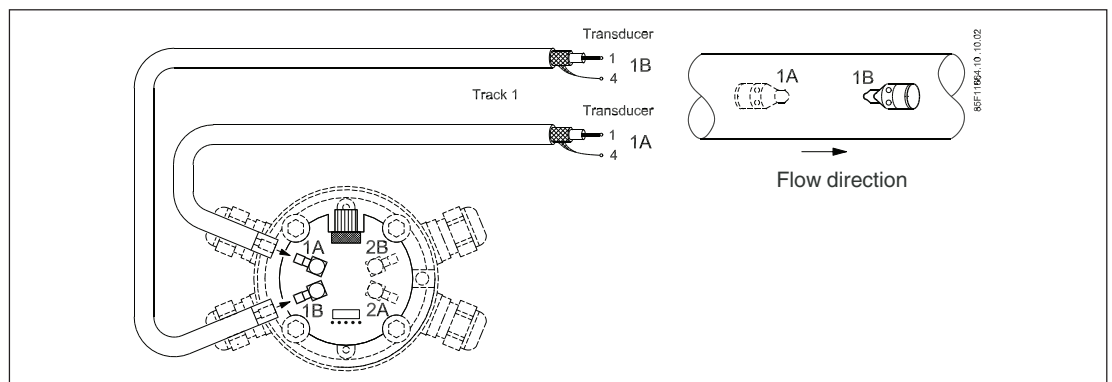

### 3.5.2 Electrical connection - transmitter to transducers (2-tracks)

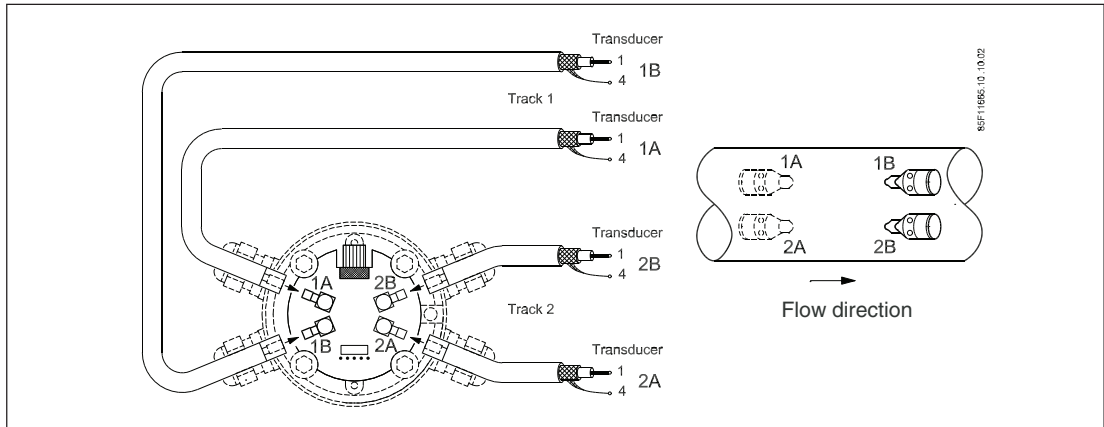

### 3.5.3 Electrical connection - allowed cable radius

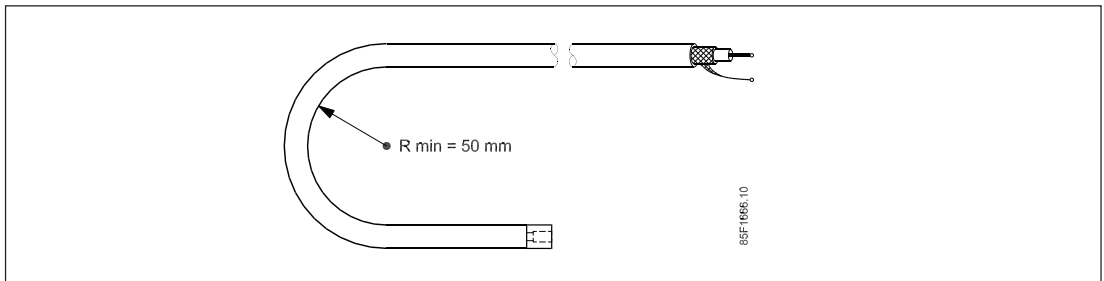

## 3.6 Rotating the operating and display panel

The operating and display panel can be turned in 90° steps to enable better reading in the case of vertical installation or overhead assembly.

#### Procedure:

- Switch off the power supply.
- Loosen the lid lock of the electronics chamber-cover with a 3-mm Allen key.
- Unscrew the cover.
- Unlock the operating and display panel carefully at the fastening hooks alternately using a screwdriver or similar tool, pull it out, turn it to the desired position and re-insert it.
- Screw the cover back on and mount the lid lock.

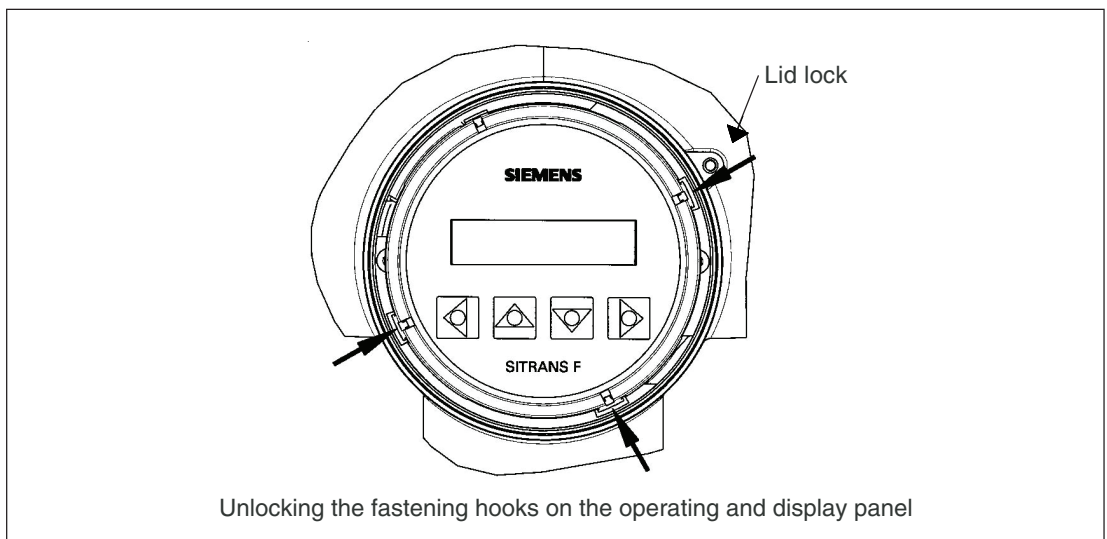

---

## 3.7 Warning



The pertinent regulations must be observed for electrical installation, in explosion risk areas in particular:

- The rules and regulations governing the erection and operation of plants in explosion risks areas (e.g. EN 60079-14).
- The EC Type Examination Certificate - Do not install the device under voltage. Danger of electric shock! -The version for power supply DC 19 to 30 V may only be connected to SELV or PELV circuits.

The SITRANS FUS060 transmitter comply with the following electrical installation categories:

- Version for 115 to 230 V AC: Installation Category II
- Version for 24 V AC/DC: Installation Category II

### General requirements:

- The power supply should be connected via a circuit breaker and fused via a fuse (max. 4 A).
- Use cables with a cross section of at least 1.5 mm<sup>2</sup> and double or reinforced insulation for the power supply.
- Lay heat-resistant cables if high temperatures can occur on the housing, eg due to conduction of heat by the sensor/metering tube. Lay the cables so that they do not come into contact with the hot sensor/metering tube.
- Lay signal cables separately from cables with voltages > 60 V.
- Use cables with twisted wire pairs.
- Full HART 5.1 specifications only with shielded cables.
- Earth transmitter housing.

### Make the electrical connection as follows:

- Cables used for connection must have diameters fitting the glands.
- Use shielded cables for the outputs
- Compare data on rating plate with local power supply.
- Release lid lock of terminal box by turning the 3 mm hexagon socket screw.
- Unscrew lid from terminal box.
- Push power cable and signal cable through cable glands up to terminal block. Lay cables in a bend in front of cable glands to prevent moisture getting into terminal block.
- Use signal cables with shielded wire pairs if analog output and pulse/frequency output are to be used simultaneously and signals are transmitted in one cable.
- For full performance at 10 KHz frequency on digital output 1, the capacitive load should not exceed 100 nF (see also technical specification for digital output 1 on pages 6 and 7).
- Make the connection. Fit end ferrules to fine wire cables.
- Connect PE cable of power supply to earth terminal ⊕ in terminal box. Use a cable length so that the PE conductor is the last one to come away when the cables are pulled.
- Mount lid for power supply terminals in devices with ignition protection ATEX II 2G Ex dem [ia/ib] T6..T3.
- Tighten cable gland and check strain relief.
- In devices with protection type ATEX II 2G Ex dem [ia/ib] T6..T3 replace unused cable glands with certified blind plugs.
- Screw lid tightly to housing, always use a tool. The sealing ring must be clean and undamaged.
- Mount lid lock.

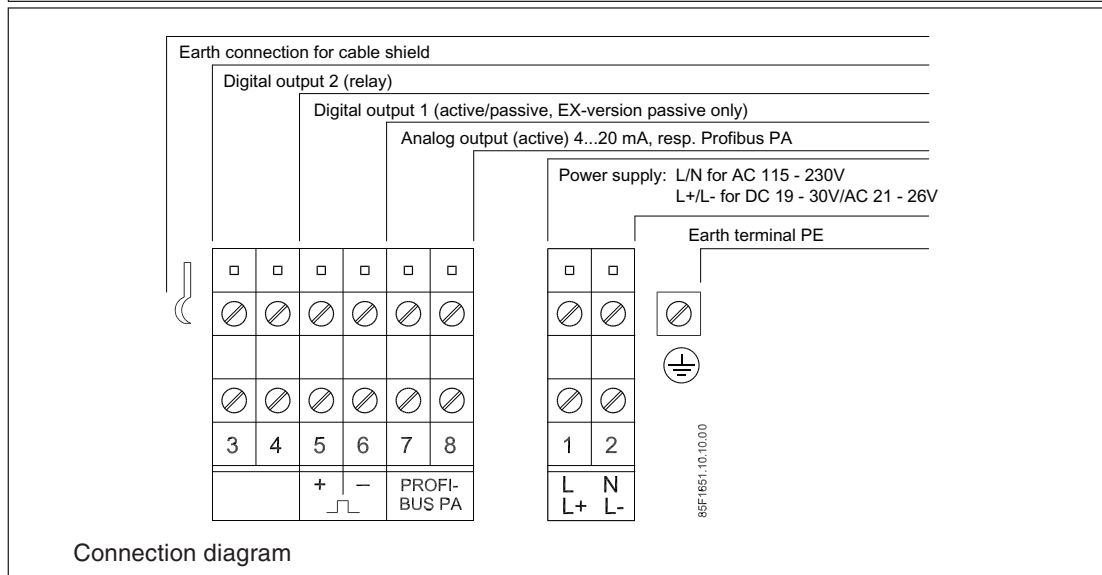
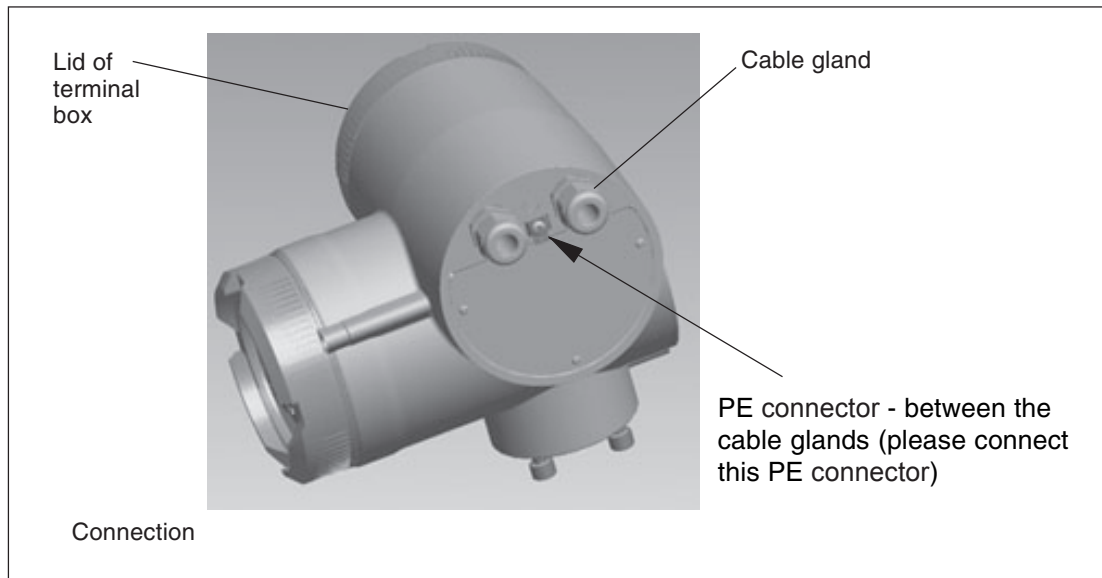

In devices with protection type ATEX II 2G Ex dem [ia/ib] T6..T3, intrinsically safe circuits must be separated from non-intrinsically safe circuits by certified safety isolators or barriers.

For reliable communication via HART-protocol at least one load of 230 Ω must be available in the signal circuit.

The FUS060 enclosure must be connected with an earth wire to the PE connector - see note in figure above.



### Warning

- Ex-version: According to the "Ex-requirements", the 'PE-terminals' on FUS060 and on sensors (SONO3200 transducers or SONO 3300 sensor) must be potential equalised (min. 4 mm<sup>2</sup>).
- The PE-terminals should always be connected to solve EMC problems (Ex-Version on non Ex).
- If device is energized (power supply, digital outputs in the case of external feeding), housing covers may not be unscrewed in areas where there is a risk of explosion.
- Lid over terminals for power supply may not be removed! Use only certified measuring instruments!



# Start up

The device is ready for operation immediately after switching on the power supply.

Be aware that a number of factory settings (eg max volume flow, angle of tracks, distance between transducers, displacement of transducer from center line of pipe) are dimension dependent. The settings are factory preset in the transmitter for SONO 3100 and SONO 3300. For SONOKIT and spare part transmitters please enter values manually.

If there is still gas/air in pipe (metering tube) or in pipeline after assembly, a "flashing" F or D may appear at the top right of the first line in the display. The failure signal is output at the analog output.

## 4.1 Electrical data connection - Ex-version

**Power supply** DC 19.2 – 30 V or  
Terminals 1 (L/L+) and 2 (L/L-) AC 20.4 – 26.4 V, approx. 10 W

**Analog output AA** (Active output)  
HART-version 4 to 20 mA Type of protection Intrinsic Safety Ex ia IIC/IIB  
Terminals 7 (+) and 8 (-)

Max. values:  
Uo = 15.8 V  
Io = 64 mA  
Po = 253 mW  
Ri = 250 Ω

### Admissible outer reactances:

	IIC				IIB				
Lo	0	0.5	2.0	9.6	0	1	5	44	[mH]
Co	470	420	360	160	2800	2600	1600	650	[nF]

**Digital output DA1** (Passive output)  
HART-variant 4 ... 20 mA  
Terminals 5 (+) and 6 (-)

**Maximum values:**  
Uo = 7.2 V  
Io = 2.2 mA  
(error condition for Co and Lo calculations)

or

type of protection Intrinsic safety Ex ia IIC/IIB

only for connection to a certified intrinsically safe circuit.

**Max. values:**  
Ui = 30 V  
Ii = 100 mA  
Pi = 750 mW  
Ci = 24 nF  
Li = 108 uH

**Digital output DA2**  
(relay output)  
Terminals 3 and 4

type of protection Intrinsic Safety Ex ia IIC/IIB

only for connection to a certified intrinsically safe circuit.

**Max. values:**

$U_i = 30 \text{ V}$   
 $i_i = 100 \text{ mA DC}$   
 $i_i = 50 \text{ mA AC}$   
 $C_i = 24 \text{ nF}$   
 $L_i = 73 \text{ uH}$

## 4.2 Operation (HART communication)

The device can be operated with:

- operating and display panel
- HART-Communicator
- PC/Laptop and software SIMATIC PDM with HART modem (coupling module)

Electrical connection of PC/Laptop with HART modem and HART-Communicators to 4 - 20 mA signal line is shown in figure below.

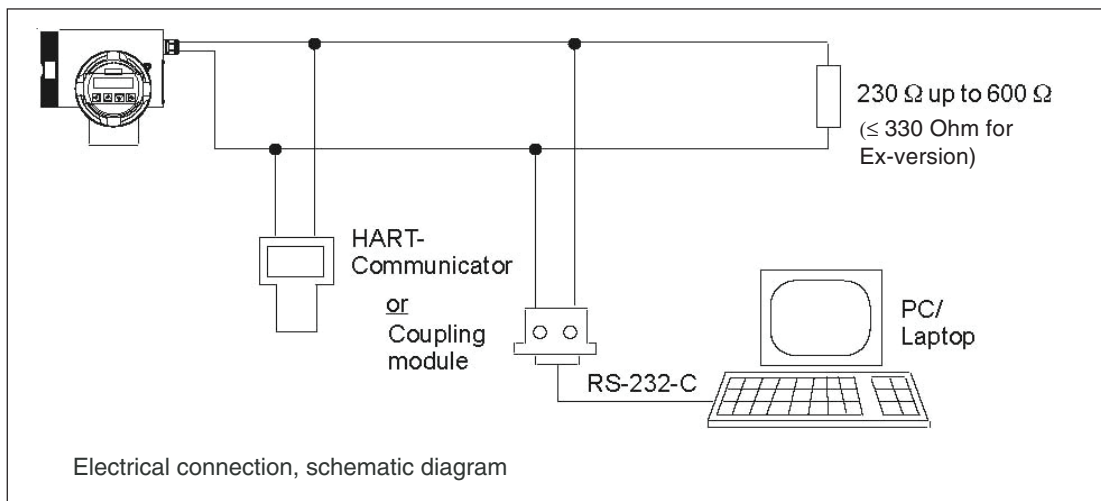

**Warning**

Do not use coupling module (HART modem) in hazardous areas and do not connect to intrinsically safe circuits.

## 5.1 Keypad and display lay-out

The device is operated with the optical keypad on the operating and display panel. These are operated by touching the appropriate fields on the glass panel with your fingertips. The individual device functions/parameters are selected and changed by alternately actuating the optical keypad with the menu-guided operation in the display.

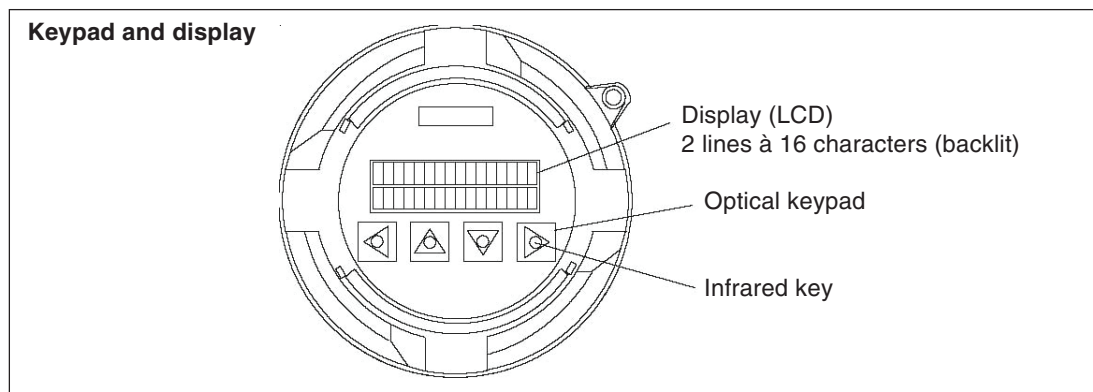

The operating structure is explained below.

## 5.2 Operating concept of operating and display panel

Operation is based on a hierarchically structured operating concept, ie all functions/parameters are grouped logically and carry a menu code number.





The seven main functions are selected in the main menu:

1. Display
2. Diagnostics
3. Measurement functions
4. Device outputs
5. Identification
6. Service
7. Sensor parameters

The individual functions and parameters for further groups are combined within these main groups.





---

The device functions and parameters available are shown in the second line of the display. Selection is made with the  and  keys. These are shown in the second line of the display. Enter device function or setting level of parameters with the  key (Enter function). It is possible to exit the selected function or setting level without storage of the change by using the  key until the cursor key moves to the far left position.

The currently valid setting appears after selecting the setting level of a parameter. If programming is enabled the programmable value flashes in the second line of the display. The parameter setting can be changed. There are two different types of data input:

- direct numerical input
- input from given table

In the numerical input, the  and  keys function as cursor control. The selected digit flashes.

The  key increases the flashing digit (eg 

9	9	.	0	0	0
---	---	---	---	---	---

 becomes 

1	0	0	.	0	0	0
---	---	---	---	---	---	---

).



The  key decreases the flashing digit (eg 

1	0	.	0	0	0
---	---	---	---	---	---

 becomes 



9	.	0	0	0	0
---	---	---	---	---	---

).

Furthermore, it is possible to move the decimal point to the right using the  key and to the left using the  key.



After selecting the last digit, the input is confirmed by using the  key. The entered value is accepted if it is within the permissible input range. In this case the user guidance returns to the selection menu for the parameters of the group concerned. If the entered value is rejected, an error message briefly appears on the display followed by the previous setting. The value can be changed again.

#### Note

- If the  or  keys are operated permanently (finger left on the glass panel) the numeric value or setting option is changed continuously in tabular selection.
- If an accidentally changed setting is wrong, it is possible to exit the menu item by actuating the  key several times (return to the next menu level up).

## 5.4 Disabling or enabling access to settings

Programming of the device by unauthorized persons can be disabled with a personal, freely selectable code in the operating and display panel. Device functions and parameters can then only be changed after entering the code. The personal code is determined in the menu item “6.2 Customer code”

If the  and  keys are actuated in the parameter setting level, the request to enter the code appears in the display. For free access, it is also possible to enter the code once in menu item “6.1 Code-Input”. The programming is disabled again:

- after returning to the display mode
- about 10 minutes after actuating the last optical keypad
- after entering any number, not the code number, in the menu item “6.1 Code-Input”

#### Note

- The programming is **always** enabled with code = 0 (factory setting).

## 5.5 Operating examples

### Example 1

Setting of menu language.

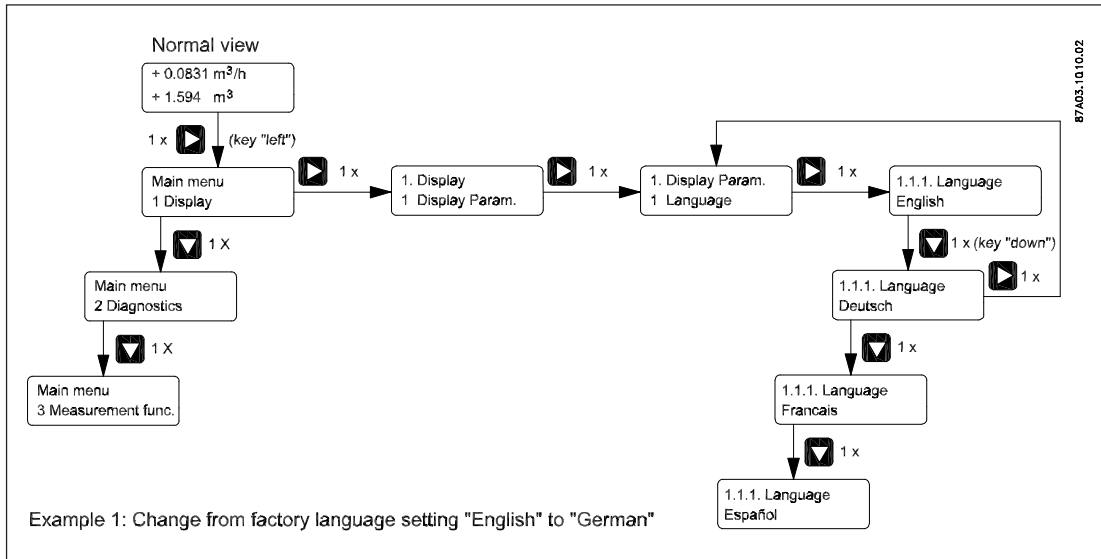

### Example 2

Change the physical unit for the flow value from m<sup>3</sup>/h to l/min. Starting point is the multi-display.

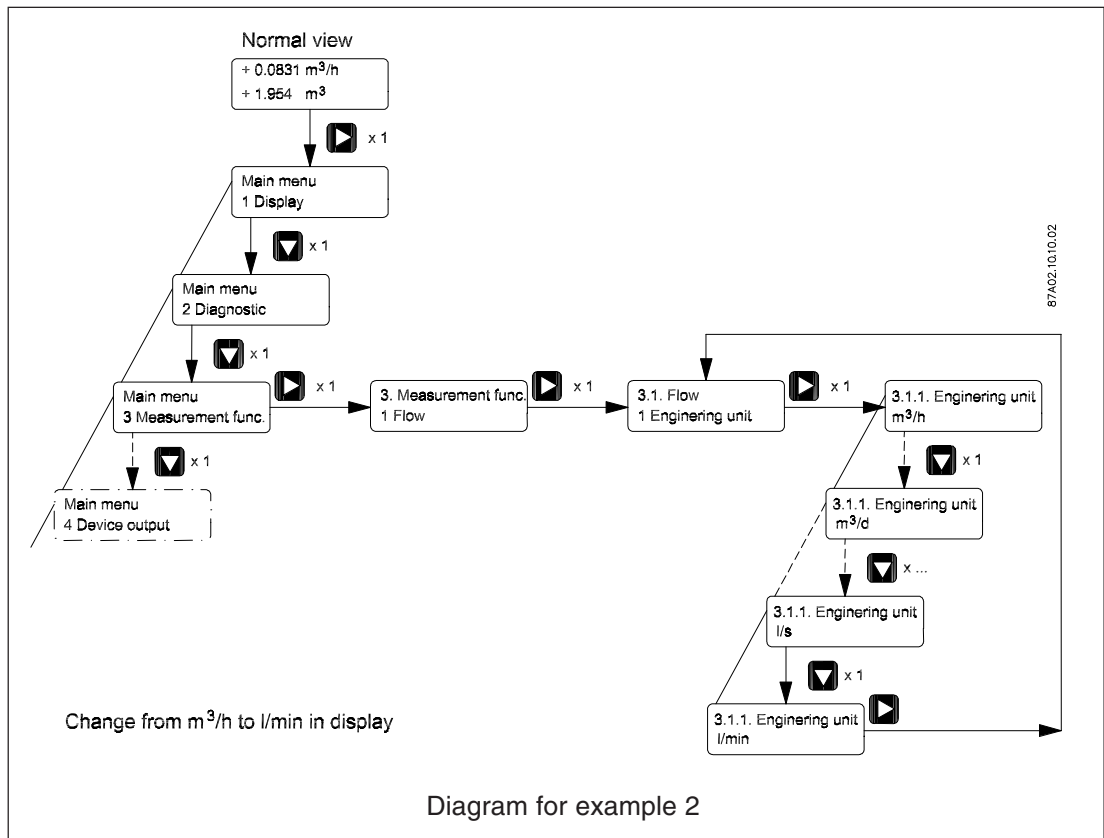

The operating path to be followed is represented in the diagram.

The optical keypads to be actuated are specified and the individual operating steps numbered consecutively.

---

### Example 2

Change pulse unit from m<sup>3</sup>/Imp to l/Imp and pulse value from 10 m<sup>3</sup>/Imp to 10 l/Imp.

The current setting appears in display.

```
4. 2.   D i g i t a l   o u t p 1
3.   P u l s e   v a l u e
```

Enable the programming.  
Second display line flashes.



```
4. 2. 3.   U n i t
m 3 / l m p
```

Scroll through using  until "l/Imp" appears in display (flashing).

```
4. 2. 3.   U n i t
l / l m p
```

Press the  key to select "l/Imp".  
Display now shows (1000.000 l/Imp)  
and first digit flashes.

```
4. 2. 3.   P u l s e   R a t e
+ 1 0 0 0 . 0 0 0 0   l / l m p
```

Press  to move cursor to the decimal point. Then move cursor 2 places to the left using .

```
4. 2. 3.   P u l s e   R a t e
+ 1 0 . 0 0 0 0   l / l m p
```

Confirm input by using  to move cursor to the far right position (enter function).

```
4. 2. 3.   P u l s e   R a t e
+ 1 . 0 0 0 0 0   l / l m p
```

Display returns to the start viewing. The change in setting is made and stored.

```
4. 2.   D i g i t a l   o u t p 1
3.   P u l s e   v a l u e
```

The normal display view is reached by repeatedly pressing the  key .

## 5.6 Setting option and factory setting in the display

Only menu items relevant for end users and simple service cases are listed in this table.

### Menu items (SW Rev. 2.01.07)

Menu number	Device function, parameter	Description	Factory setting	Setting options	Read or write	Hart
<b>1.</b>	<b>Display</b>					
1.1	Display parameter	Setting of actual display parameter readings				
1.1.1	Language	Language in display	English	english deutsch francais español	Write	
1.1.2	Line 1	Parameter value in line 1	Flow	Flow Total. net Total. forward Total. reverse Flow velocity Sound velocity US-Amplitude Analog output Frequency	Write	
1.1.3	Line 2	Parameter value in line 2	Total. net	Flow Total. net Total. forward Total. reverse Flow velocity Sound velocity US-Amplitude Analog output Frequency	Write	
1.1.4	Display Flow	Select presentation	Physical Unit	Physical units % Diagram (Bar in %)	Write	
1.1.5	LCD lighting	Switch LCD on/off (automatic switch off after 10 min.)	Off	On Off	Write	
1.1.6	Multi display	Display of two measured values in lines 1 and 2	Line 1: Flow Line 2: Totalizer	See menu 1.1.2 See menu 1.1.3	Read	
<b>1.2</b>	<b>Flow</b>					
1.2	Flow	Flow in metering tube	Actual metering value	For unit see menu 3.1.1	Read	
<b>1.3</b>	<b>Totalizer</b>					
1.3.1	Total. forward	Totalizer forward	Actual value is shown	Units selectable in menu 3.4.1	Read	
1.3.2	Total. reverse	Totalizer reverse	Actual value is shown	Units selectable in menu 3.5.1	Read	
1.3.3	Total net	Totalizer difference Forward - reverse	Actual value is shown	Units selectable in menu 3.6.1	Read	
1.3.4	Settings (all)	All totalizers will be set to zero. (Independent setting of totalizers in menu 3.4, 3.5, 3.6)	No action	No action Reset + stop Reset + start	Write	
<b>1.4</b>	<b>Flow velocity</b>					
1.4	Flow velocity	Flow velocity in metering tube	Actual value is shown	m/s (range -12 to +12 m/s)	Read	
<b>1.5</b>	<b>Sound velocity</b>					
1.5	Sound velocity	Sound velocity in medium	Actual value is shown	m/s	Read	
<b>1.6</b>	<b>Amplitude US</b>					
1.6	Amplitude US	Relative ultrasonic amplitude of received ultrasonic signals (reference water). Depending on tracks activated (up to 4 values).	Actual value is shown	Display in %	Read	
<b>1.7</b>	<b>Frequency</b>					
1.7	Frequency	Frequency output value	Actual value is shown	Hz	Read	



Menu number	Device function, parameter	Description	Factory setting	Setting options	Read or write	Hart
<b>1.8</b>	<b>Current output</b>					
1.8	Current output	Current value of analogue output	Actual value is shown	mA	Read	
<b>2.</b>	<b>Diagnostics</b>					
<b>2.1</b>	<b>Device status</b>					
2.1	Device status	Error messages are shown	"OK"	Only read See table in chapter 6.2	Read	
<b>2.2</b>	<b>Suppress error</b>					
2.2	Suppress error (not stored)	Switch off error message with effect on: Analog output Digital output 1 Digital output 2	None	None Unreliable flow Measuring path disturbed Both	Write	
<b>2.3</b>	<b>Device test</b>					
2.3.1	Self test	Test device status	"OK"		Read	
2.3.2	Display test	Visual LCD test			Read	
<b>2.4</b>	<b>Simulation</b>					
2.4.1	Flow Value  Time	Simulation of flow. Simulation value. Affects all outputs and totalizers. Duration of simulation. After expiration of this time the normal measuring mode is resumed.	0%  End (no action)	-110.... + 110%  End (no action) 10 min 30 min 60 min	Write  Write	
2.4.2	Digital output 1	Simulation of output signal for digital output 1	End (no simulation) 0.1 Hz 1 Hz 10 Hz 100 Hz 1 kHz 10 kHz Alarm on Alarm off	End (no simulation)	Write	
2.4.3	Digital output 2	Simulation of output signal for digital output 2 (relay)	End (no simulation)	End (no simulation) Alarm on Alarm off	Write	
2.4.4	Analog output	Simulation of output current of analogue output	4 mA	4 mA 10 mA 12 mA 20 mA Error signal	Write	
<b>3.</b>	<b>Meas. function</b>					
<b>3.1</b>	<b>Flow</b>					
3.1.1	Unit	Physical units for volume flow, mass flow <b>Note:</b> Whenever using mass flow - actual density have to be selected in menu 3.1.4	m <sup>3</sup> /h	l/s, l/min, l/h, m <sup>3</sup> /s, m <sup>3</sup> /min, m <sup>3</sup> /h, m <sup>3</sup> /d, Ml/d, ft <sup>3</sup> /s, ft <sup>3</sup> /min, ft <sup>3</sup> /h, ft <sup>3</sup> /d, gal/s, gal/min, ImpGal/s, ImpGal/min, ImpGal/h, ImpGal/d, g/s, g/min, kg/s, kg/min, kg/h, kg/d, ton/min, ton/h, ton/d, lb/s, lb/min, lb/h, lb/d, LTon/d, STon/min, STon/h, STon/d	Write	
3.1.2	Max. vol. flow	Full scale value <b>Note:</b> Corresponds to 20 mA and selected max. frequency	Depends on sensor size	See dimension table in sensor manual	Write	
3.1.3	Limits	Flow unit according to menu 3.1.1				
3.1.3.1	Lo alarm limit	Lower alarm limit (lower limit must be lower than upper limit)	Depends on sensor size	See dimension table in sensor manual	Write	
3.1.3.2	Hi alarm limit	High alarm limit (higher limit must be higher than lower limit)	Depends on sensor size	See dimension table in sensor manual	Write	
3.1.3.3	Hysteresis	Hysteresis for limit in % of full scale value	1%	0%...20%	Write	

Menu number	Device function, parameter	Description	Factory setting	Setting options	Read or write	Hart
3.1.4	Density Units	Density of media Density unit	kg/m <sup>3</sup>	g/cm <sup>3</sup> g/l kg/l kg/m <sup>3</sup> lb/ft <sup>3</sup> lb/in <sup>3</sup> lb/gal lb/lmpgal	Write	
	Density	Input of density value for arithmetic calculation of mass flow	+1000.00 kg/m <sup>3</sup>	200...5000 kg/m <sup>3</sup>	Write	
3.1.5	Direction					
3.1.5.1	Direction	Determination of main direction of flow (forward direction)	+ Direction	+ Direction - Direction	Write	
3.1.5.2	Measurement	Choice of measurement direction	Forward only	Forward only Forward + reverse	Write	
3.1.5.3	Hysteresis	Setting hysteresis for flow direction related to full scale value	1%	0...20%	Write	
3.1.6	Low flow cut	Determination of switching point for low flow cut-off. Suppression is related to full scale value	1%	0...20%	Write	
3.1.7	Flow damping					
3.1.8	Time constant	Selection of time constants for measuring variables	5.0 sec	0.0...200 sec	Write	
<b>3.2</b>	<b>Sound velocity</b>					
3.2.1	Dynamic range	Unit for sound velocity	m/s	m/s	Read	
3.2.2	Dynamic range					
3.2.2.1	Lower value	Lower range value for sound velocity Lower range value < Upper range value	+600 m/s	+200...2000 m/s	Write	
3.2.2.2	Upper value	Upper range value for sound velocity Upper range value > Lower range value	+2000 m/s	+200...2000 m/s	Write	
3.2.3	Limits					
3.2.3.1	Lo alarm limit	Lower alarm limit Lower alarm limit < Upper alarm limit	+200 m/s	200...2000 m/s	Write	
3.2.3.2	High alarm limit	Upper alarm limit Upper alarm limit > Lower alarm limit	+2000 m/s	200...2000 m/s	Write	
3.2.3.3	Hysteresis	Hysteresis for limit	5%	0...20%	Write	
3.2.4	Time constant	Selection of time constant for measuring variable	5 s	0...200 s	Write	
<b>3.3</b>	<b>Amplitude US</b>					
3.3.1	Dynamic range					
3.3.1.1	Lower value	Lower range value for ultrasonic amplitude Lower range value < Upper range value	1%	1 ...150%	Write	
3.3.1.2	Upper value	Upper range value for ultrasonic amplitude Upper range value > Lower range value	100%	1...150%	Write	
3.3.2	Limits				Read	
3.3.2.1	Lo alarm limit	Lower alarm limit	1%	1%...150%	Write	
3.3.2.2	Hi alarm limit	Higher alarm limit	120%	1%...150%	Write	
3.3.2.3	Hysteresis	Hysteresis for limit	1%	0...20%	Write	
3.3.3	Time Constant	Filter time constant	+10.00 s	0...200 s	Write	

Menu number	Device function, parameter	Description	Factory setting	Setting options	Read or write	Hart
<b>3.4</b>	<b>Totalizer forward</b>					
3.4.1	Unit	Physical volume unit or mass unit. <b>Note:</b> Whenever using mass flow the actual density have to be selected in menu 3.1.4	m <sup>3</sup>	l hl m <sup>3</sup> Ml ft <sup>3</sup> Gal MGal ImpGal MImpGal g kg Ton lb	Write	
3.4.2	Hi alarm limit	Upper limit of alarm	+1.000.000.000 m <sup>3</sup>	0...1.000.000.000	Write	
3.4.3	Setting forward	Volume totalizer reset to "0" and "stop/start"	No action	No action Reset + stop Reset + start	Write	
<b>3.5</b>	<b>Total. reverse</b>					
3.5.1	Unit	Physical volume unit or mass unit <b>Note:</b> Whenever using mass flow the actual density have to be selected in menu 3.1.4	m <sup>3</sup>	l hl m <sup>3</sup> Ml ft <sup>3</sup> Gal MGal ImpGal MImpGal g kg Ton lb	Write	
3.5.2	Lo alarm limit	Vallue for lower limit of alarms	-1.000.000.000	-1.000.000.000...0	Write	
3.5.3	Setting reverse	Volume totalizer reset to "0" and "stop/start"	No action	No action Reset + stop Reset + start	Write	
<b>3.6</b>	<b>Forward - reverse volume</b>					
3.6.1	Total.net unit	Physical volume unit or mass unit Note: Whenever using mass flow the actual density have to be selected in menu 3.1.4	m <sup>3</sup>	l hl m <sup>3</sup> Ml ft <sup>3</sup> Gal MGal ImpGal MImpGal g kg Ton lb	Write	
3.6.2	Lo Alarm Limit	Value for lower alarm limit	-1.000.000.000 m <sup>3</sup>	-1.000.000.000...0	Write	
3.6.3	Hi Alarm Limit	Value for upper alarm limit	+1.000.000.000 m <sup>3</sup>	0...1.000.000.000	Write	
3.6.4	Hysteresis	Hysteresis for the limits	0	0...3	Write	
3.6.5	Settings net	Volume totalizer reset to "0" and "stop/start"	No action	No action Reset + stop Reset + start	Write	
<b>4.</b>	<b>Device outputs</b>					
<b>4.1</b>	<b>Analog output</b>					
4.1.1	Analog output	Assignment of a measured variable to output signal	Flow Sound Velocity US-amplitude	Flow	Write	
4.1.2	Current limit	Upper current limit	20.5 mA	20.0 to 22.5 mA	Write	

Menu number	Device function, parameter	Description	Factory setting	Setting options	Read or write	Hart
4.1.3	Error signal	Output current in case of error. Use of "hold" in X s means current will be kept for X seconds	3.6 mA	3.6 mA 22 mA 24 mA Hold: 5s, 20s, 40s, 60s, 120s, 240s, hold continuously	Write	
4.1.4	Current output	Actual current of analog output in mA depending on choice in menu 4.1.1, 4.1.2 and 4.1.3			Read	
4.1.5	Flow range %	Actual measurement in % of selection in menu 4.1.1		0%	Read	
<b>4.2</b>	<b>Digital output 1</b>	<b>Frequency or impulse signal for flow or alarm signal</b>				
4.2.1	Function	Assignment of output function	Pulse	Pulse Frequency Alarm Flow dir. forward Flow min Flow max Flow min/max Total forw. max Total rev. min Total net. min Total net max No function	Write	
4.2.2	Signal type	Configure output: Signal: active or passive Logic: positive or negative	Passive-pos.	Active-pos Active-neg Passive-pos Passive-neg	Write	
4.2.3	Pulse value Unit	Physical unit per impulse (only necessary if "Pulse" is used)	m <sup>3</sup> /Imp	l/Imp m <sup>3</sup> /Imp Gal/Imp ImpGal/Imp kg/Imp t/Imp lb/Imp 0...1000.0	Write	
	Pulse rate	Number of volume units per impulse (only necessary if "Pulse" is used)	1 m <sup>3</sup> /Imp		Write	
4.2.4	Pulse width	Setting pulse width (only necessary if "Frequency" is used)	0.10 ms	0.1...2000 ms	Write	
4.2.5	Full scale freq.	Full scale frequency	10000 Hz	2...10 000 Hz	Write	
<b>4.3</b>	<b>Digital output 2 (relay)</b>					
4.3.1	Function	Assignment of output function	Alarm Flow dir. forward Flow min/max Flow min Flow max Min/max US-vel Max US-vel Min US-vel Min/max US-ampl Max US-ampl Min US-ampl No function	Alarm	Write	
4.3.2	Signal type	Logic of signal output in case of function in menu 4.3.1	Contact opens	Contact closes Contact opens	Write	
<b>5.</b>	<b>Identification</b>					
<b>5.1</b>	<b>Unit identity</b>					
5.1.1	Tag	Tag number on metering unit	To be defined by user	Hart: max 8 charac.	Write	
5.1.2	Descriptor	Tag number description	To be defined by user	Hart: max 16 charac.	Write	
5.1.3	Message	Messages to tag	To be defined by user	Hart: max 32 charac.	Write	

Menu number	Device function, parameter	Description	Factory setting	Setting options	Read or write	Hart
<b>5.2</b>	<b>Manuf. Ident.</b>					
5.2.1	Product type	Product type, Order number		Read only	Read	
5.2.2	Serial number	Serial number		Read only	Read	
5.2.3	Software rev.	Software revision	2.01.07 (Previous 2.01.04)	Read only	Read	
5.2.4	Manuf. date	Manufacturing date - DD.MM.YYYY		Read only	Read	
5.2.5	Nominal size	Sensor size	Depending on diameter, only informal detail, no influence on measurements	Read only	Read	
5.3	Device ID (HART address)	True identification in HART long address	0		Read	
<b>6.</b>	<b>Service</b>					
<b>6.1</b>	<b>Enter code</b>	Entering the 4 digit code selected in menu 6.2 in order to change user parameters	0	0...9999 According to setting in menu 6.2	Write	
<b>6.2</b>	<b>Customer Code</b>	Selection of a personal code. Code 0: User parameter are not protected. Code>0: User parameters are protected under menu 6.	0	0...9999	Write	
<b>6.3</b>	<b>Service code</b>	Only for service in the Siemens factory			Write	
<b>6.4</b>	<b>Reset</b>	Re-start of unit without change of parameters	Cancel	Cancel Reset	Write	
<b>6.5</b>	<b>Control values</b>					
6.5.1	Gain	Gains of the single tracks				
6.5.1.1	Gain up 1	Gain of first track up		0-255	Read	
6.5.1.2	Gain dw 1	Gain of first track down		0-255	Read	
6.5.1.3	Gain up 2	Gain of second track up		0-255	Read	
6.5.1.4	Gain dw 2	Gain of second track down		0-255	Read	
6.5.1.5	Gain up 3	Gain of third track up		0-255	Read	
6.5.1.6	Gain dw 3	Gain of third track down		0-255	Read	
6.5.1.7	Gain up 4	Gain of fourth track up		0-255	Read	
6.5.1.8	Gain dw 4	Gain of fourth track down		0-255	Read	
6.5.2	Amplitudes	Amplitudes of the single tracks				
6.5.2.1	Ampl up 1	Amplitude of first track up		0-255 (Optimum: 95-105)	Read	
6.5.2.2	Ampl dw 1	Amplitude of first track down		0-255 (Optimum: 95-105)	Read	
6.5.2.3	Ampl up 2	Amplitude of second track up		0-255 (Optimum: 95-105)	Read	
6.5.2.4	Ampl dw 2	Amplitude of second track down		0-255 (Optimum: 95-105)	Read	
6.5.2.5	Ampl up 3	Amplitude of third track up		0-255 (Optimum: 95-105)	Read	
6.5.2.6	Ampl dw 3	Amplitude of third track down		0-255 (Optimum: 95-105)	Read	
6.5.2.7	Ampl up 4	Amplitude of fourth track up		0-255 (Optimum: 95-105)	Read	
6.5.2.8	Ampl dw 4	Amplitude of fourth track down		0-255 (Optimum: 95-105)	Read	

Menu number	Device function, parameter	Description	Factory setting	Setting options	Read or write	Hart
6.5.3	Trigger/Level	Trigger-level of the individual tracks				
6.5.3.1	Trig up 1	Trigger-level of first track up		0-255	Read	
6.5.3.2	Trig dw 1	Trigger-level of first track down		0-255	Read	
6.5.3.3	Trig up 2	Trigger-level of second track up		0-255	Read	
6.5.3.4	Trig dw 2	Trigger-level of second track down		0-255	Read	
6.5.3.5	Trig up 3	Trigger-level of third track up		0-255	Read	
6.5.3.6	Trig dw 3	Trigger-level of third track down		0-255	Read	
6.5.3.7	Trig up 4	Trigger-level of fourth track up		0-255	Read	
6.5.3.8	Trig dw 4	Trigger-level of fourth track down		0-255	Read	
6.5.4	Error count %					
6.5.4.1	Error 1	Error totalizer in % for track 1		0-100% Optimal: 0%	Read	
6.5.4.2	Error 2	Error totalizer in % for track 2		0-100% Optimal: 0%	Read	
6.5.4.3	Error 3	Error totalizer in % for track 3		0-100% Optimal: 0%	Read	
6.5.4.4	Error 4	Error totalizer in % for track 4		0-100% Optimal: 0%	Read	
6.5.5	TOF up	TIME OF FLIGHT (TOF) upstream of the individual tracks				
6.5.5.1	TOF up 1	TIME OF FLIGHT (TOF) of first track upstream		Value in ns	Read	
6.5.5.2	TOF up 2	TIME OF FLIGHT (TOF) of second track upstream		Value in ns	Read	
6.5.5.3	TOF up 3	TIME OF FLIGHT (TOF) of third track upstream		Value in ns	Read	
6.5.5.4	TOF up 4	TIME OF FLIGHT (TOF) of fourth track upstream		Value in ns	Read	
6.5.6	TOF down	TIME OF FLIGHT (TOF) downstream of the individual tracks				
6.5.6.1	TOF down 1	TIME OF FLIGHT (TOF) of first track udownstream		Value in ns	Read	
6.5.6.2	TOF down 2	TIME OF FLIGHT (TOF) of second track downstream		Value in ns	Read	
6.5.6.3	TOF down 3	TIME OF FLIGHT (TOF) of third track downstream		Value in ns	Read	
6.5.6.4	TOF down 4	TIME OF FLIGHT (TOF) of fourth track downstream		Value in ns	Read	
6.5.7	Delta TOF	TIME OF FLIGHT (TOF) difference				
6.5.7.1	Delta TOF 1	TIME OF FLIGHT (TOF) difference of first track (up - down)		Value in ns	Read	
6.5.7.2	Delta TOF 2	TIME OF FLIGHT (TOF) difference of second track (up - down)		Value in ns	Read	
6.5.7.3	Delta TOF 3	TIME OF FLIGHT (TOF) difference of third track (up - down)		Value in ns	Read	
6.5.7.4	Delta TOF 4	TIME OF FLIGHT (TOF) difference of fourth track (up - down)		Value in ns	Read	

Menu number	Device function, parameter	Description	Factory setting	Setting options	Read or write	Hart
<b>6.6</b>	<b>Zero Trim</b>	Zero point values for track1 to track 4				
6.6.1	Zero Pt.Offset	Zero offset compensation value for each track				
6.6.1.1	Zr.Pt.Offset 1	Zero offset of first track	+0.000 ns	-50.000 ns....+50.000 ns	Read	
6.6.1.2	Zr.Pt.Offset 2	Zero offset of second track	+0.000 ns	-50.000 ns....+50.000 ns		
6.6.1.3	Zr.Pt.Offset 3	Zero offset of third track	+0.000 ns	-50.000 ns....+50.000 ns	Read	
6.6.1.4	Zr.Pt.Offset 4	Zero offset of fourth track	+0.000 ns	-50.000 ns....+50.000 ns	Read	
6.6.2	Stand.Dev.	Standard deviation value for each track			Read	
6.6.2.1	Stand.Dev.1	Standard deviation for track 1	+0.000 ns		Read	
6.6.2.2	Stand.Dev.2	Standard deviation for track 2	+0.000 ns			
6.6.2.3	Stand.Dev.3	Standard deviation for track 3	+0.000 ns		Read	
6.6.2.4	Stand.Dev.4	Standard deviation for track 4	+0.000 ns		Read	
6.6.3	Zero Trim "Start sero tr."	Initiates a device specific adjustment cycle (zero trim processing) that determines the true zero point value. <b>Only during no-flow process conditions!</b>		Shows as "Zero status": "start", "running" and "finished"	Write	
6.6.4	Undo zero tr.	Undo last zero trim		After choice shows "Zero Trim OK"	Write	
<b>7.</b>	<b>Sensor Param.</b>					
7.1	Sensor calib	Sensor calibration				
7.1.1	Calib choice	Calibration choice	Auto	Wet Auto	Write	
7.1.2	App. param.	Application parameters				
7.1.2.1	Viscosity	Viscosity of media	0.01 cm <sup>2</sup> /s	0.005...5 cm <sup>2</sup> /s	Write	
7.1.2.2	Correct. fact.	Gain compensation value for flow sensor	1.0	0.000001...100	Write	
7.1.2.3	Fl. offset comp.	Offset compensation value for flow sensor (in flow unit) (in the menu 3.1.1 closed unit)	+0.00000 m <sup>3</sup> /h		Write	
7.1.2.4	Cable len. TOFKOR	Total cable length for a track. All tracks must have the same length	Depending on selection (factory setting with the ordered transducer cable length)	0...500 m	Write	
7.1.3	Pipe geometry	Pipe geometry				
7.1.3.1	Pipe diameter	Inside diameter of pipe	Depending on selection	0.01...4.0 m	Write	
7.1.3.2	Roughness	Roughness of the inner pipe wall	0.4 mm	0.01...10.0 mm	Write	
7.1.4	Tracks	Settings of individual tracks				
7.1.4.1	Track 1	Settings of track 1				
7.1.4.1.1	Length 1	Length of track 1	Depending of sensor size	>0...8.0 m	Write	
7.1.4.1.2	Angle 1	Angle of track 1	Depending of sensor size	0..89 °	Write	
7.1.4.1.3	Displacement 1	Displacement of track 1	Depending of sensor size	0...1.5 m	Write	
7.1.4.2	Track 2	Setting of track 2				
7.1.4.2.1	Length 2	Length of track 2	Depending of sensor size	>0...8.0 m	Write	
7.1.4.2.2	Angle 2	Angle of track 2	Depending of sensor size	0..89 °	Write	
7.1.4.2.3	Displacement 2	Displacement of track 2	Depending of sensor size	0...1.5 m	Write	

Menu number	Device function, parameter	Description	Factory setting	Setting options	Read or write	Hart
7.1.4.3	Track 3	Settings of track 3				
7.1.4.3.1	Length 3	Length of track 3	Depending of sensor size	>0...8.0 m	Write	
7.1.4.3.2	Angle 3	Angle of track 3	Depending of sensor size	0...89 °	Write	
7.1.4.3.3	Displacement 3	Displacement of track 3	Depending of sensor size	0...1.5 m	Write	
7.1.4.4	Track 4	Setting of track 4				
7.1.4.4.1	Length 4	Length of track 4	Depending of sensor size	>0...8.0 m	Write	
7.1.4.4.2	Angle 4	Angle of track 4	Depending of sensor size	0...89 °	Write	
7.1.4.4.3	Displacement 4	Displacement of track 4	Depending of sensor size	0...1.5 m	Write	
7.2	No. of tracks	Number of active tracks in sensor	1-track or 2-tracks	1-track 2-tracks 3-tracks 4-tracks	Write	



The following sections describe some device function parameters in the table that need further explanations.

### 6.1 Main menu: Display (menu 1)



#### Note

#### Backlight setting

**Off:** Light turns off 3 min after last key action.

**On:** On for 1 hour after last key action.

#### Totalizer reset menu 3.4.3, 3.5.3, 3.6.5

The individual totalizers can be reset to zero with this menu. Selection takes place with the  and  keys.

For all three totalizers the following possibilities exist:

- No action
- Reset + stop
- Reset + start

Reset + stop, means the totalizer will be stopped and reset.

Reset + start, means the totalizer will continue after reset of totalizer.

In the “1.3 Totalizer“ menu the total flow quantity is displayed. The display appears as a volume or mass depending on the selection volume unit/mass unit in menus 3.4, 3.5, and 3.6.

The menu is divided as follows:

3.4 - Volume forward or mass forward (flow quantity in positive flow direction)

3.5 - Volume reverse or mass reverse (flow quantity in negative flow direction)



3.6 - Net volume or net mass (positive flow quantity minus negative flow quantity)

In menus “3.4.3”, “3.5.3”, “3.6.5”, and “Totalizer reset” the totalizer can be reset to zero - either with stop of the totalizer or reset and on-going totalizer.

#### Menus 1.7 and 1.8

The arithmetically calculated output variables are displayed in the menu “Current output” and “Frequency” irrespectively of whether the output is used.

#### Language selection, menu 1.1.1

If language is to be other than English – press 4 x  (yellow key) and change language into preferred language with  key.

---

## 6.2 Main menu: Diagnostics (menu 2)

### Device status, menu 2.1

2.1	Device status	Error message	“Ok”	See failure table “Error message” below
-----	---------------	---------------	------	---

The test-routines are systematically executed during normal operation. The error is indicated by a blinking notice on display:

- **D:** Device error
- **F:** Process error

The error can be shown on the analog and digital outputs.

The error is described by the variable status\_display (menu 2.1). The error messages and their assignment to the display notice, analog output, and digital outputs are noted in the table.

**Table - Error messages**

Error message	Blinking notice on the display	Error message on	
		Analog output	Digital output 1, and 2
Measuring path error	F	√ <sup>3)</sup>	√
Unreliable flow value	F	√ <sup>3)</sup>	√
COM module failure <sup>1)</sup>	D	-	-
Measurement module failure	D	√	√
EEPROM failure	D	√	√
RAM failure	D	√	√
SSC failure <sup>2)</sup>	D	-	√
Firmware failure	D	√	√

1) HART-module

2) Internal serial interface

3) Failure signal is not output if error is eliminated

### Suppress error, menu 2.2

In this menu item, error messages such as “Illegal flow measurement” and/or “Measuring path disturbed” are eliminated so that no error message is read neither on the display nor at the current output. After every reset of the device all error messages are available again, thus this menu setting is not stored.

### Device test, menu 2.3

The following test routines are available:

#### Self test, menu 2.3.1

The self test routines test the hardware and has a duration of about 10 sec.

If there is no error, “OK” is displayed, otherwise “not OK”. The type of error can be read in the menu item “2.1 Device Status”.

#### Display test, menu 2.3.2

The LCD is checked with this menu item. The display is dark for about 5 seconds at first and then bright for about 5 seconds.

#### Simulation, menu 2.4

Signal circuits of analog output and digital outputs 1 and 2 can be checked here. The value to be simulated can be selected in the individual menu. The setting becomes active after confirming the selected value.

## 6.3 Main menu: Measuring functions (menu 3)

The range and limit values can be displayed as follows:  
Volume flow (volume unit per time) or mass flow (mass unit per time).

The volume flow  $q_v$  is converted to mass flow  $q_m$  with the density entered ( $q_m = q_v \cdot \rho$  in menu "Density").

Depending on the selection made, the quantities in menu "1.3 Totalizer" are specified in the function group "Display".

### Flow, sound velocity and amplitude US: Menu 3.1, 3.2 and 3.3

The measuring variables flow, sound velocity or ultrasonic amplitude can be assigned to the analog output and the limit value message to digital output 2. The appropriate measuring ranges and limit values are set in the subsequent sub-menus.

Every sub-menu is further divided for setting the subsequent values.

- Measuring range full scale value
- Measuring range start of scale value (omitted for flow, start of scale = 0)
- Limit value max (upper limit value)
- Limit value min (lower limit value)
- Hysteresis
- Damping (Filter time constant)

The selection made here defines the unit for several parameters simultaneously:

- for volume or mass flow: Measured value display, measuring range and limit value formation
- for volume or mass: Display, totalizer reading and pulse valency.

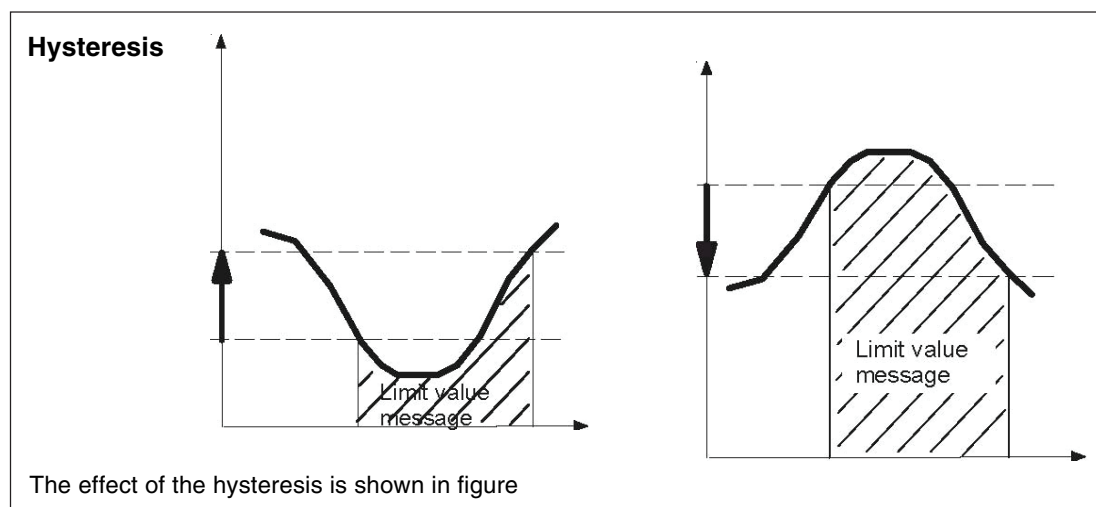

### Density, menu 3.1.4

The physical unit is selected in menu 3.1.4.

After entering units the display will automatically step into "Density".

The density of the medium is entered in this menu (step 2) to convert the volume flow to mass flow (see also menu "3.1.1 Units").

### Note

Input of density is unnecessary and ineffective when "Volume flow" setting has been selected in menu "3.1.1 Units".

### Direction, menu 3.1.5.1

Determination of the main flow direction.

### Measurement direction, menu 3.1.5.2

SITRANS FUS060 is able to measure in both flow directions (forward and reverse) or in forward direction only. The selection is made by the setting.

- forward + reverse
- forward only

If “forward” is parameterized, signals are only output or accumulated internally for a flow in this direction.

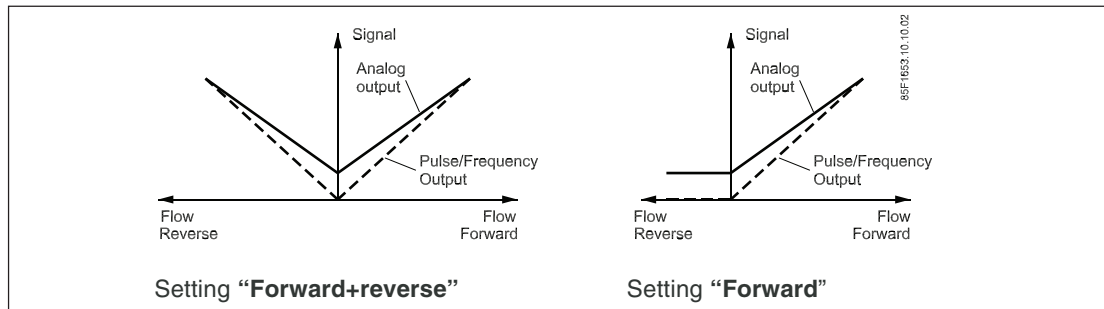

### Hysteresis of flow, menu 3.1.5.3

Signalling of flow direction can operate with a hysteresis determined by the user. The setting is made in % of full scale value in menu item “3.1.5.3 Hysteresis”. If, for example, the hysteresis is 1%, the relay contact does not switch until flow is  $-1\%$  of full scale value and it returns to its original position when flow is  $+1\%$  of full scale value.

The operating principle of the relay (digital output 2), contact open or closed in forward flow-direction is determined in menu item “4.3.2 Signal Type”.

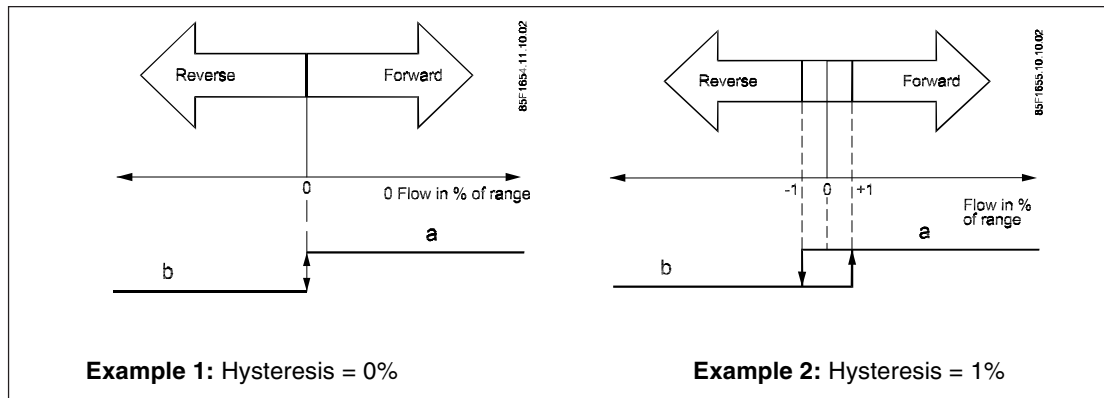

The other hysteresis menus are of the same principle.

### Note

The low flow cut off suppression has no influence on signalling of flow direction.

## 6.4 Main menu: Device output (menu 4)

The analog output is only active for devices with HART interface.

### Analog output select

4.1.1	Analog output select	Assignment of a measured variable to output signal	Flow	Flow Sound velocity US amplitude
-------	----------------------	--	------	--

There are three types of measurements which can be assigned to the analog output:

- Flow
- Sound velocity
- US amplitude

### Current limit, menu 4.1.2

The upper current limit for the output signal is determined in this menu item.

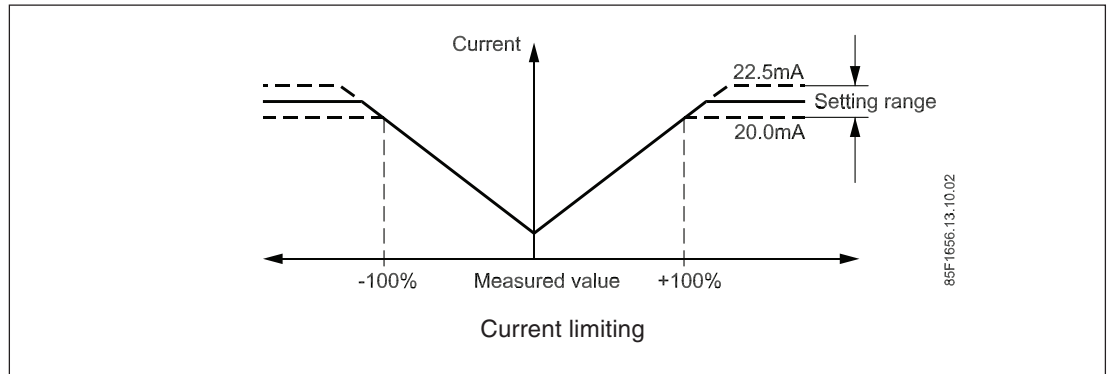

### Error signal, menu 4.1.3

In case of an error (see table “Error messages”) the analog output has one of the following error signals:

The following settings are possible:

- 3.6 mA
- 22 mA
- 24 mA
- Hold for a defined time (5, 20, 40, 60, 120 or 240 seconds), then 3.6 mA
- Hold continuous

With the “Hold 5 s” setting, brief disturbances (e.g. air entrapped in the medium) can be bridged for about 5 seconds without an error message via the analog signal.

The same applies for “Hold 20 s”, “Hold 40 s” etc.

The last valid measured value is output during the disturbance. If the disturbance lasts less than 5 s the current measured value is output after 5 seconds. If the disturbance persists (eg disturbance lasts longer than 5 s), the output signal is set to 3.6 mA after 5 seconds.

In the “Hold continuous” setting, the last valid value is output for as long as the disturbance persists, helpful in the configuration is the possibility of selectively suppressing error messages, see menu 2.2.

## Digital output 1 menu 4.2

### Function menu 4.2.1

The digital output 1 (implemented for both HART and PA interfaces) can indicate flow (impulse or frequency) and some alarms/limits.

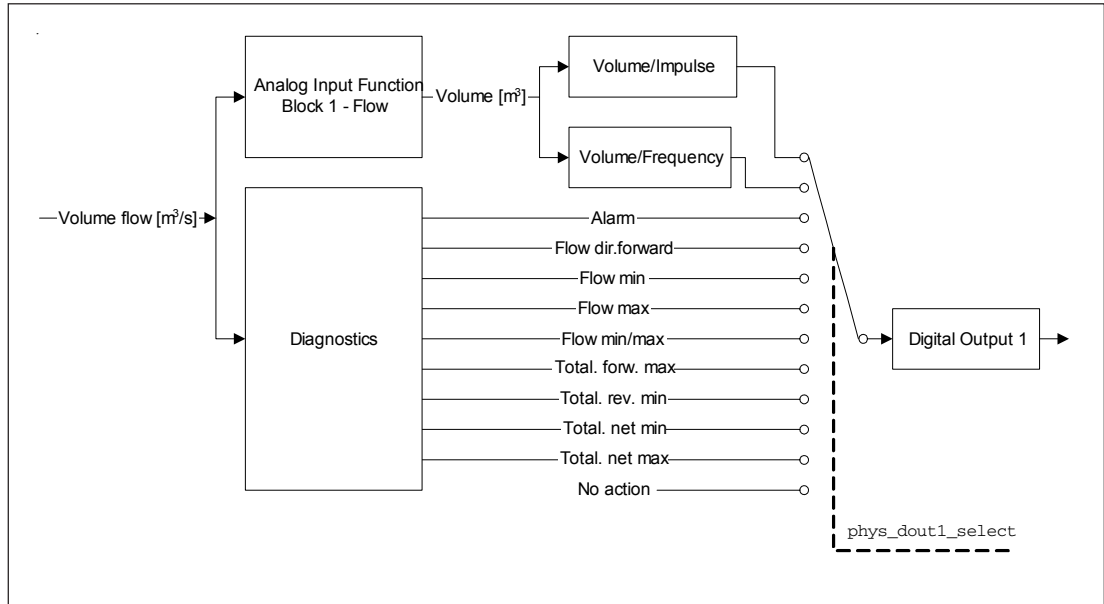

### Signal type, menu 4.2.2

Different signal types can be configured for the output signal of digital output 1.

- Active: Device-internal voltage used (+24 V).
- Passive: External supply necessary.

In the device version with protection type ATEX II 2G Ex dem [ia/ib] IIC T6..T3 with intrinsically safe output only passive:

HART: Active or passive. PROFIBUS: Only passive.

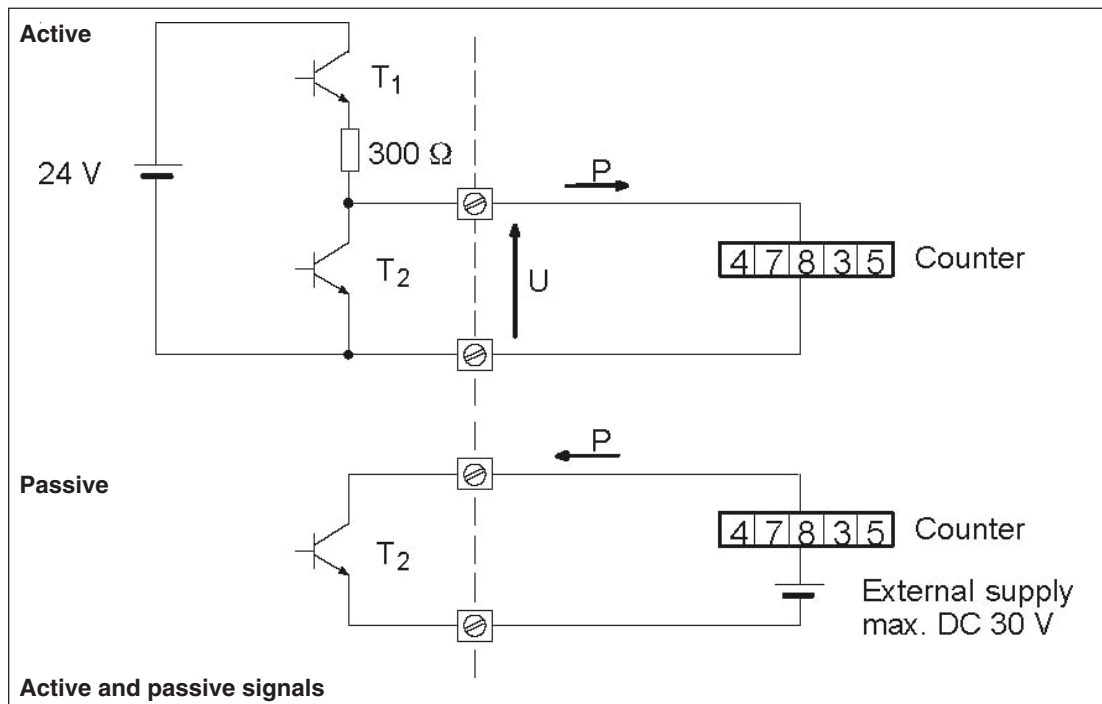

Signals with positive and negative logic can be generated (positive or negative pulses). Figure explains setting options.

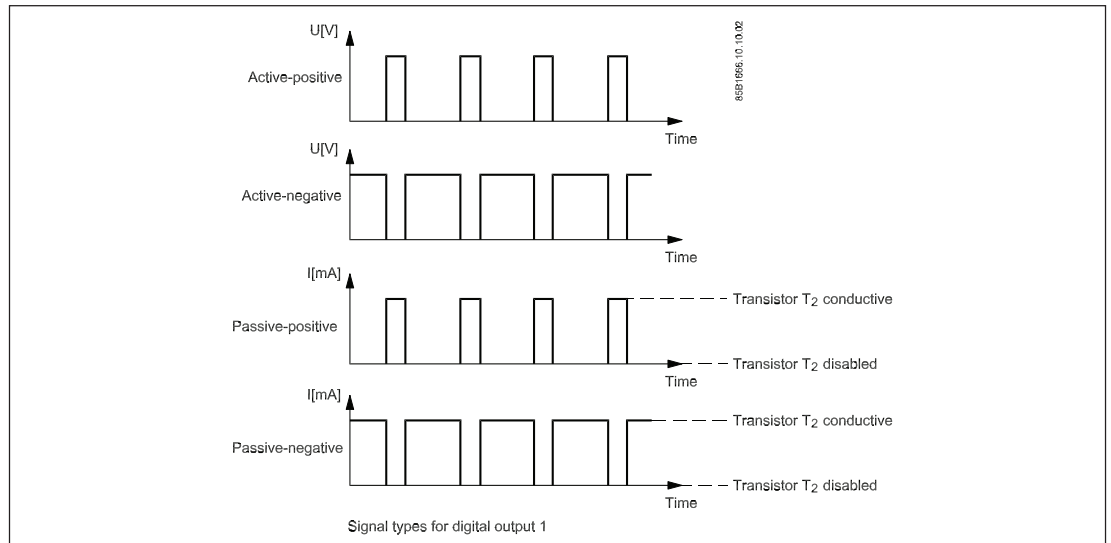

### Pulse output

Pulses are converted in a volume/impulse or mass/impulse block. There are two parameters to be set for the impulse output in the menu which are used in this block:

- **Pulse rate, menu 4.2.3:** For example this value determines how many cubic meters flowing through it takes to make one impulse. By setting of this value it is possible to change the unit (unit/impulses) to make setting of the pulse volume easier.
- **Pulse width, menu 4.2.4:** The impulse width can be set in the range from 0.1 to 2000 ms. The maximum impulse width is computed according to the set flow upper value. The maximum frequency for impulse output is 5 kHz.

### Full scale frequency, menu 4.2.5

The output frequency is converted from volume in a volume/frequency block. The frequency is fixedly assigned to the volume. The duty cycle rate is constant 50%. The frequency for the flow upper value is given by the variable.

### Digital output 2 relay, menu 4.3

The digital output 2 is configured and parameterized with this menu.

### Function, menu 4.3.1

The digital output 2 (relay contact) can be configured for reporting device status (device fault, measuring error), flow direction or a limit for flow, US velocity, US amplitude.

Possible alarm states are as follows:

- Alarm - device state status
- Flow direction forward
- Flow min - flow below lower limit
- Flow max - flow above upper limit
- Flow min/max - flow either under below limit or above upper limit
- Min/max US velocity
- Max US level
- Min US level
- Min/max US amplitude
- Max US amplitude
- Min US amplitude
- No function

### Note

The relay contact is open when “no function” is set.

### Signal type menu 4.3.2

The function of the relay is determined in this menu item:



Contact closes: Relay contact closes at

- Alarm message Selection in menu “4.3.1 Function”
- Flow in forward-direction
- Limit signal

Contact opens: Relay contact opens at

- Alarm message Selection in menu “4.3.1 Function”
- Flow in forward-direction
- Limit signal

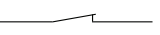
The table explains relay logic.

Setting	No alarm Reverse flow No limit signalling	Alarm message Forward flow Limit signalling
Contact closes		
Contact opens		

Switching status of the relay

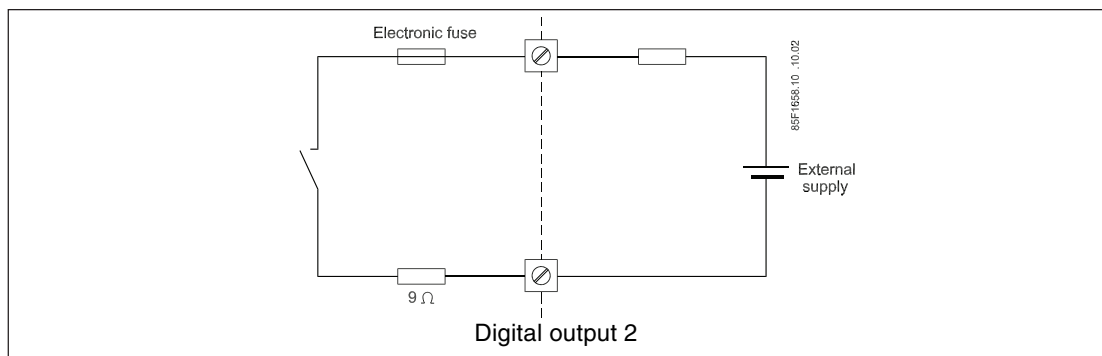

The electronic fuse is tripped in the event of overloading. The recovery time of the fuse is a few minutes.



---

## 6.5 Main menu: Identification (menu 5)







### Unit identity, menu 5.1

Device-specific or tag-specific data can be called or entered in this menu.





Tag number, menu 5.1.1

Tag description, menu item 5.1.2

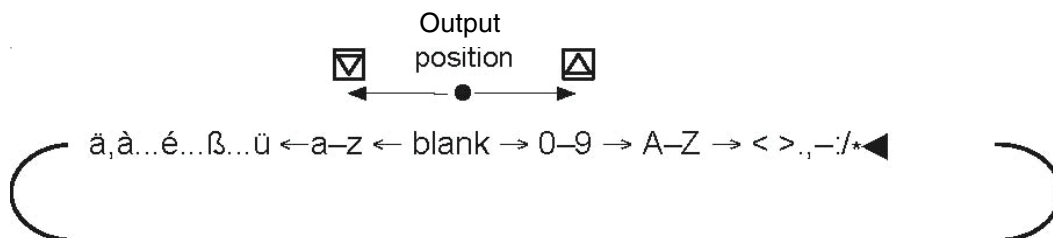
Tag message, menu item 5.1.3



Tag-specific data can be entered in these menu items. The  and  keys functions as cursor control here. Numbers, letters and text characters are selected with the  and  keys. If no text is stored, the end of text-character < flashes in the first segment when you enter these menu items. By actuating the  and  keys, the end of text-character moves one position to the right and one character can be selected from the character set. The following characters are available:





The selected character is entered by actuating the  key and the end of text character flashes again. Another character can be selected with the  and  key. The text input is ended by actuating the  key when the end of text character flashes.



The number of characters is limited to:

- Tag number: 20 characters (8 characters in HART)
- Tag description: 20 characters (16 characters in HART)
- Tag message: 32 characters

For texts longer than 16 characters the marks < and > in the first and last segment indicate that there are further characters to the left and/or right of the displayed text section. These are displayed by actuating the  and  keys.

Deleting texts: Select the end of text character from the character set with the  and  keys and then actuate the  key. All entries to the right of the end of text character are deleted.

### Note

If the  and  keys are actuated continuously (finger continuously touching the glass panel), the characters are automatically scrolled.

### Manufacturer identity, menu 5.2

The serial number, MLFB order number and software version of the device can be read in the individual menu items.

### Nominal size, menu 5.2.5

The nominal pipe size is entered in this menu item. It is not possible to change the nominal size without the factory code.

---

## 6.6 Main menu: Service (menu 6)

### Enter code, menu 6.1

Programming of the device by unauthorized persons can be disabled with a customer specific code (range 0...9999) in the operating and display panel. By entering the appropriate code in this menu item, the programming is enabled and the device settings can be changed.

- Customer code (from factory the customer code is set to "0").

### Note

- If the  or  key is actuated in the parameter setting level with the programming disabled, the request for "Enter code" appears in the device display (when user code #0).
- The programming is disabled after returning to the display mode after 10 min (when user code #0).
- Programming can be purposely disabled by entering any number, not the code number, in this menu item (when user code #0).

### Customer code, menu 6.2

The personal code with which programming of the device can be enabled is entered or changed in this menu item. The code is factory set to 0. The menu item is only accessible after entering the personal code even when programming has already been enabled.

**Attention!** The programming is always enabled when the code = 0.

### Service code, menu 6.3

The calibration data of the device are protected by a special code (factory code). The appropriate menu items are available only after entering the service code. In normal application cases, keying in the factory code is not necessary.

### Reset, menu 6.4

A reset of the unit can be made without change of parameters. (Warm restart).  
Totalizers will not be erased.

### Control values, menu 6.5

In this menu, device-internal data used mainly for error diagnosis for max 4-tracks can be read. The values displayed in the individual menu depend on the respective application (medium). The following data are available:

- Gain
- Amplitudes
- Trigger level
- Error %
- Time of flight - up
- Time of flight - down
- Amplitude
- Difference in time of flight (TOF)

---

### Gain, menu 6.5.1

Every transducer gain - level can be read.

These parameters are read only values and within the range of 0...255.

Unused tracks will show 0. Normal values are in the range of 10 to 100. High gain values refer to a high sound absorption in the medium (max 255 for no sonic transfer).

### Amplitudes, menu 6.5.2

This value shows the peak amplitude of the selected US-track in digital units from 0 ... 255 which means 0...5 V. Optimum values are between 95 and 105. Worst possible values are close to 0.

### Trigger-levels, menu 6.5.3

The trigger level is used to recognize the ultrasonic signal. The trigger-level will be calculated from the last signal level amplitude.

### Error count %, menu 6.5.4

The menu shows the ERROR COUNTER in % for each track.

### Time of flight (TOF), menu 6.5.5

The time of flight is the time the ultrasonic signal takes to travel from one transducer to the other. The time of flight is dependent on sensor size, angle, media and temperature of the media.

### Time of flight difference, menu 6.5.7

The time of flight difference is the measured difference: TOF up – TOF down.

---

## 6.7 Main menu: Sensor parameters (menu 7)

### Important:

**All sensor characteristics in menu 7 are determined and preset at the factory. They should not be changed for flow meter systems with sensor types SONO 3100 and SONO 3300.**

For SONOKIT the FUS060 transmitter is preset at the factory according to the SONOKIT order codes (pipe dimension, number of tracks). The exact sensor pipe dimension (from the "SONOKIT - SENSOR GEOMETRY MEASUREMENT REPORT") must be entered in menu 7.

### Sensor calibration, menu 7.1

#### Calibration choice

7.1.1	Calib. choice	The calibration choice	WET	WET or AUTO
-------	---------------	------------------------	-----	-------------

As is shown in menu 7.1.1 - calibration choice, the switching between WET and AUTO has a big influence on the calibration and calculation of the flow value.

If AUTO selected is, the calibration constants will be taken from geometrical data entered from the SONOKIT Measurement report.

When this automatic calibration is used, several more sensor characteristics will be combined and calculated to form the internal calibration factor. These calculated calibration factors for tracks 1, 2, 3, and 4 are then read only parameters which are accessible via PDM only.

---

**SONOKIT uses "AUTO"** to determine the calibration factors based on input of:

- Pipe diameter
- Length from transducer front to transducer front of every track
- Displacement of each sound track from center of pipe
- Average angle of every track
- Length of used cable in one sound track
- Roughness inside the pipe
- Viscosity of measured media

**Note**

Automatic calibration can only be used for ordinary round shape pipes.

**Nice to know:**

When WET selected is, the calibration parameters will be taken from the factory calibration process. These parameters will be stored in special WET calibration parameters (eg SONO 3100 and SONO 3300 sensors). In this case the factory predefined data should not be changed.

**Note**

Please use AUTO calibration mode for all SONOKIT systems. For SONO 3100 and SONO 3300 "Wet" calibration should always be chosen.

**Media viscosity, menu 7.1.2.1**

7.1.2.1	Viscosity	The viscosity	0.01 cm <sup>2</sup> /s	0.005 ... 5 cm <sup>2</sup> /s
---------	-----------	---------------	-------------------------	--------------------------------

The viscosity value will be used in the flow constant formula.

The viscosity is default set to 0.01 cm<sup>2</sup>/s (normal water).

**Correction factor, menu 7.1.2.2**

This is a user parameter that can be used to adjust the calculated flow.

**Offset compenstation, menu 7.1.2.3**

The offset compensation is equal to the addition of a constant flow. This can be used for service purposes.

**Cable length-time of flight, menu 7.1.2.4**

The transmitter is always installed in a remote position. Therefore it is necessary to enter the length of the sensor cable in order to compensate for the time delay occurring in the cables. The cable length is **the total length of the signal cable in one sound track**. The measuring unit of the cable length is meters. The tolerance is ±0.5 m.

**Pipe diameter, menu 7.1.3.1**

This value represent the average inside diameter of the actual pipe.

**Note**

**All sensor charachteristics in menus 7.1.3.x are determined and preset at the factory. They should not to be changed for flow meter systems with sensor types SONO 3100 and SONO 3300.**

**For SONOKIT the FUS060 transmitter is preset at the factory according to the SONOKIT order codes (pipe dimension, number of tracks). The exact sensor pipe dimension (from the "SONOKIT - SENSOR GEOMETRY MEASUREMENT REPORT") must be entered.**

**Roughness, menu 7.1.3.2 (to be changed for SONOKIT only)**

Roughness is the value for the surface inside the pipe.

The range of this value is defined to 0.01 mm to 10.0 mm because standard Siemens sensors have a roughness of approximately 0.4 mm.

Smooth plastic pipe	0.1 mm
Polished stainless steel pipe	0.1 mm
Standard carbon steel pipe	0.4 mm
Rusty carbon steel pipe	1...2 mm
Concrete pipe	2...5 mm

**Tracks, menu 7.1.4 (to be changed for SONOKIT only)**

This menu is for the parameters which are for the track settings. In the following table only the parameters for track 1 are explained.

The parameters for tracks 2, 3, and 4 are to be handled like track 1.

**Note**

The menus 7.1.4.1.x.x and 7.2 are not for flowmeter systems with sensors SONO 3100 and SONO 3300. Please do not change these values. They are determined and preset at the factory.

**Track 1, menu 7.1.4.1.1 and menu 7.1.4.2.1 (to be changed for SONOKIT only)**

**For SONOKIT: Data to be entered from "SENSOR GEOMETRY MEASUREMENT REPORT"**

Length 1

7.1.4.1.1	Length 1	The length of the first track	0.2 m	>0 m ... 8.0 m
-----------	----------	-------------------------------	-------	----------------

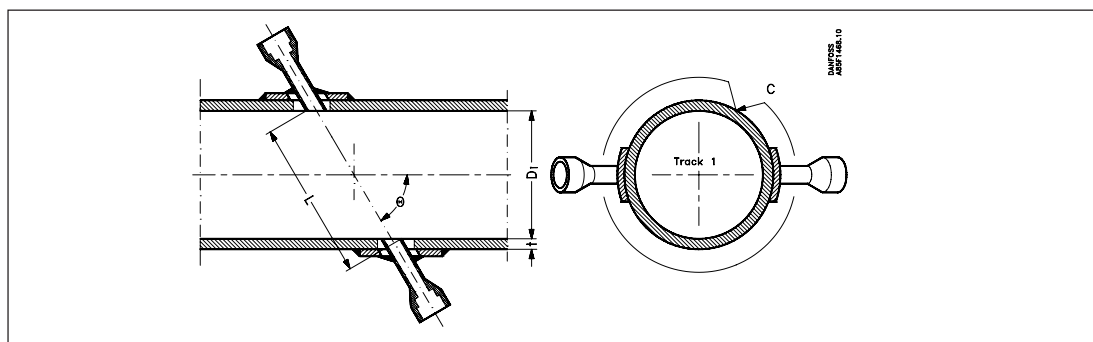

This parameter is the distance between the ultrasonic transducers, as illustrated in the picture. The value is necessary in order to calculate the ultrasonic velocity from the time of flight and the distance between the transducers.

**Angle 1, menu 7.1.4.1.2 and menu 7.1.4.2.2 (to be changed for SONOKIT only)**

Angle of track 1.

It is not necessary to enter this menu is not necessary for flowmeter systems with sensors SONO 3100 and SONO 3300. These values are determined and preset at the factory.

**For SONOKIT: Data to be entered from "SENSOR GEOMETRY MEASUREMENT REPORT"**

**Displacement, menu 7.1.4.1.3 and menu 7.1.4.2.3 (to be changed for SONOKIT only)**  
Distance “h” between soundtrack and centre of pipe.

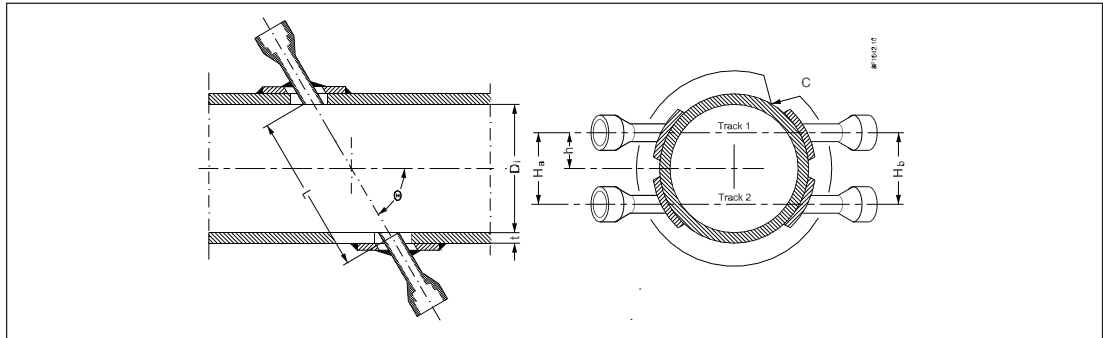

For SONOKIT: Data to be entered from “SENSOR GEOMETRY MEASURING REPORT”  
If it is a 2-track SONOKIT, use same procedure for track 2.

For flow meters with sensors type SONO 3100 and SONO 3300 the factory settings should not be changed.

**Numbers of tracks, menu 7.2**

The number of tracks preset from factory is shown. If necessary, this can be changed to 1, 2, 3 or 4-tracks.

For flow meters with sensors type SONO 3100 and SONO 3300 the factory settings should not be changed.

---

## 6.8 Procedure for entering data into the SITRANS FUS060 transmitter:

The FUS060 transmitter default set up enables the transmitter to be used for SONOKIT applications or for the replacement of an older ultrasonic flowmeter transmitter type, e.g. SONO 3000 with the FUS060. For SONOKIT with FUS060 the factory settings are according to ordered pipe dimension.

### Note

**This procedure is not for flowmeter systems with FUS060 transmitters which are delivered or calibrated together with sensors SONO 3100 and SONO 3300. Please do not change these values. They are preset from factory.**

The following procedure describes the necessary parameters/data to be entered and the sequence of entering them in order to configure the transmitter correctly for a given pipe application:

The pipe data are taken from the "SONOKIT" measurement report or from another information / data sheet of the existing sensor / calibration report.

### Measurement:

1. Enter the sensor diameter ( $D_i$ ) (menu 7.1.3.1).  
**Note: If  $D_i$  is smaller than registered, setting in menu 9 (displacement for each track) must be changed first.**
2. Choose appropriate engineering unit for flow (menu 3.1.1).
3. Enter maximum volume flow (menu 3.1.2).
4. Choose "AUTO" for calibration choice (menu 7.1.1).
5. Enter viscosity for media, otherwise the default value ( $0.01 \text{ cm}^2/\text{s}$  for water  $20 \text{ }^\circ\text{C}$ ) will be used (menu 7.1.2.1).
6. Enter inside roughness of the sensor pipe, otherwise the default value (0.4 mm) will be used (menu 7.1.3.2) (see also chapter 8.7).
7. Enter the measured transducer distance for each track (menu 7.1.4.1.1 (track 1) and menu 7.1.4.2.1 (track 2)).
8. Enter the measured angle for each track (menu 7.1.4.1.2, (track 1) and menu 7.1.4.2.2 (track 2)).
9. Enter the measured displacement for each track (menu 7.1.4.1.3, (track 1) and menu 7.1.4.2.3 (track 2)). Enter 0 for tracks not used.
10. Check the number of tracks (menu 7.2). They are preset from factory according to order).
11. Go to service menu and check that control values for amplitude (menu 6.5.2.X) have a value within the interval 90 – 110.
12. Go to service menu and check that control values for error counters (menu 6.5.4.X) are 0.
13. Go to service menu and check that control values for time-of-flight (menu 6.5.5.X) have a stable value which may vary in the nanosecond range (for example  $\pm 10\text{ns}$ ).
14. Make sure that 0 flow conditions are applied and thereafter the 0 point calibration procedure is activated by use of menu 6.6.3 ("Zero trim").
15. Calculation of flow can be corrected by use of the customer correction factor (menu 7.1.2.2) which is a scaling factor.

Based on the entered data the transmitter is capable of measuring and calculating the actual flow. The accuracy of the system at this stage is dependent on e.g. the entered accuracy of the geometry data.

## Eliminating process errors

Only two general groups of errors are shown in the display. “**Process error**” and “**device error**”. Device errors describe hardware errors. Two main groups of errors are:

### Measuring path disturbed

The medium in the measuring line is not permeable to sound, this applies both when the pipe is filled with gas or is empty. The measured value on the display is set to zero. Cable is broken or detached.

### Flow measurement unreliable

The measured values have a very high dispersion so that errors in the measuring evaluation or disturbances in the flow due to cavitation, twist or inhomogeneity such as bubbles or foreign bodies.

Measured values are displayed but an “F” flashes in the right hand corner of the display.

Error/Symptoms	Diagnosis	Solution/Comment
Display shows 0 flow. A flashing “F” appears in the display continuously/occasionally.	Pipe not filled with liquid	Make sure that the pipe is filled or at least the sound path is covered with liquid.
Device status (menu 2.1): “Measurement path disturbed”	Cable broken/detached	Make sure that the transducer cable is connected in the terminal housing of the transmitter.
Gain (menus 6.5.1.X) for the active tracks > 250		Make sure that the screen and center pin is connected inside the transducer top.
Time-of-flight (menu 6.5.5.X and 6.5.6.X) for the active tracks is not stable	Permanent disturbance inside the pipe	If possible, make sure that the transducer window inside the pipe is not damaged or that no permanent disturbance is present.
Error counters (menu 6.5.4.X) not equal to 0		
Flow not stable. A flashing “F” appears in the display continuously/occasionally. Device status (menu 2.1): “Unreliable flow value”	Air bubbles or particles of any kind disturbing the measurement	Make sure that the pipe line is ventilated and that the concentration of particles is limited to a level at which normal measurement with the meter is possible.
Gain (menus 6.5.1.X) for the active tracks < 250 but not stable	Cable partly connected	Make sure that the transducer cables are connected in the transmitter and in the sensors (SONO 3200 or SONO 3300). Check the connection of the cable screening.
Time-of-flight (menu 6.5.5.X and 6.5.6.X) for the active tracks is not stable		Make sure that the screen and center pin is connected inside the transducer top.
Error counters (menu 6.5.4.X) not equal to 0	Ultrasonic echoes	Make sure that the entered track lengths correspond with the measurement report.



<b>Error/Symptoms</b>	<b>Diagnosis</b>	<b>Solution/Comment</b>
Device displays negative flow	Interchange of transducer cable connections	Make sure that the transducer cables are connected correctly: 1A → 1A 1B → 1B 2A → 2A 2B → 2B
	Wrong setting of measurement direction	Make sure that the setting of menu 3.1.5.1 is "+ direction".
Current output does not work	Internal electrical failure (open circuit, short circuit etc.)	Start simulation on the current output by use of menu 2.4.4. The instrument for measuring the current is coupled in series with the output (across the terminals).
Pulse/Frequency output does not work	Internal electrical failure (open circuit, short circuit etc.)	Start simulation on the pulse/frequency output by use of menu 2.4.2. The frequency measuring instrument is coupled directly on the terminals.
Relay output does not work	Internal electrical failure (open circuit, short circuit etc.)	Start simulation on the relay output by use of menu 2.4.3. The instrument for measuring the resistance is coupled directly on the terminals.
Device displays 0 flow. Device status: "OK"	Process flow value is very low compared with the low flow cut off limit of the device	Check the low flow cut off (menu 3.1.6), e.g. for testing, is set to 0.
LCD display dark or partly dark (missing characters)	Internal electrical failure (open circuit, short circuit etc.)	Turn off power. Check the connections for the power supply PCBA and the flat cable for the display module. Start display test (menu 2.3.2) in case of partly dark display.
Operation with infrared keys not possible	Light interference	Check that display is not dirty. Check that display lid is locked (PDM force control). Bright auxiliary tools may be of assistance.

The SITRANS F ultrasonic flowmeter is maintenance-free.

A replaceable device fuse (slow blow 1.6 A/250 VH (switch off capacity 1500 A); license: UR, CSA, VDE) is located on the power supply board.

The following messages are output in the event of a device error or measuring error:

- The output signal selected in menu item 3.4.3 is output at the analog output.
- A message is output at digital output 1 and 2 when the outputs are configured for the alarm message.
- The message “D” appears in the display within the display menu for device errors or the message “F” for measuring errors.

If you send in the ultrasonic flowmeter to Siemens for repairs, please enclose a note bearing the following information.

- Description of the measuring job
- Error description
- Chemical and physical properties of the medium

Please use the form on the following page.

### **Warning**

All residue of the medium must be removed before sending in the device. This is particularly necessary when the medium poses a health risk such as caustic, toxic, carcinogenic, radioactive etc.

The address is:  
Siemens Flow Instruments A/S  
Nordborgvej 81  
DK-6430 Nordborg  
Denmark

## 8.1 Technical information on the application

(please add sketch of installation)

<b>To:</b> Siemens Flow Instruments A/S - A & D, SC PS 3 DK-6430 Nordborg Tel.: 0045 74 88 52 52 Fax: 0045 74 49 00 66	<b>From company:</b>  Tel.: Fax:
---	---

<b>Liquid</b>	Chemical formula:	
	Name of liquid:	
	Concentration:	
	Density:	
	Viscosity at 20°C	[mPa s]
	Viscosity process temperature	
<b>Flow measurement range</b>		Typical limits:
<b>Nominal size [m]</b>		
<b>Process temperature</b>		+200°C to -200°C
<b>Ambient temperature (transmitter)</b>		-20°C to +50°C
<b>Pressure</b>		Max PN 40
<b>Gas/solid content</b>		< 1% / 3%
<b>Explosion protection</b>		

<b>Serial-No.</b>		Menu 5.2.2
<b>Order No.</b>		Menu 5.2.1
<b>Software version</b>		Menu 5.2.3
<b>Device status, error message, frequency, ...</b>		Menu 2.1
<b>Flow</b>		Menu 1.2
<b>Flow velocity</b>		
<b>Sound velocity</b>		
600 [m/s] ≤ c <sub>Medium</sub> ≤ 2000 [m/s]		Menu 1.5
<b>Ultrasonic amplitude</b> [%]		Menu 1.6
<b>Flow velocity</b> [m/s]		Menu 1.4
<b>Frequency output</b> [Hz]		Menu 1.7
<b>Analog output</b> [mA]		Menu 1.8
<b>Upper range value for flow</b>		Menu 3.1.2
<b>Flow damping</b>		Menu 3.1.7
<b>Low flow cut-off</b>		Menu 3.1.6
<b>Analog output: Error signal</b>		Menu 4.1.3
<b>Current limit</b>		Menu 4.1.2
<b>Gain</b> 0 .... 255		Menu 6.5.1
<b>Trigger level</b> 0 .... 255		Menu 6.5.3
<b>Error count %</b> 0 .... 100 %		Menu 6.5.4
<b>Time of flight up</b> [ns]		Menu 6.5.5
<b>Time of flight down</b>		Menu 6.4.6
<b>Delta TOF</b> [ps]		Menu 6.5.7
<b>Amplitude</b> 0 .... 255		Menu 6.5.2

All certificates are posted on the Internet. Additionally, the Declaration of Conformity as well as approvals are available on the SITRANS F literature CD-ROM

See also

Certificates (<http://www.siemens.com/processinstrumentation/certificates>)

We have checked the contents of this manual for agreement with the hardware and software described. Since deviations cannot be precluded entirely, we cannot guarantee full agreement. However, the data in this manual are reviewed regularly and any necessary corrections included in subsequent editions. Suggestions for improvement are always welcomed.

Technical data subject to change without prior notice.

The reproduction, transmission or use of this document or its contents is not permitted without express written authority. Offenders will be liable for damages. All rights, including rights created by patent grant or registration of a utility model or design, are reserved.

Copyright © Siemens AG 11.2009 All Rights Reserved